

TQHA Show Committee presents



April 29-May 3, 2026

Tennessee Miller Coliseum
Murfreesboro, Tennessee

Where good horses come to compete

The background of the page is decorated with several equestrian items. On the left, there is a brown leather bridle with gold-colored metal accents and a yellow bell. On the right, there is a close-up of a metal bit. At the bottom, there is a close-up of a metal horseshoe. The items are arranged in a way that they appear to be floating or scattered around the central text.

2026

PATTERN BOOK

L1, Junior, L1 Amateur, L1 Youth TRAIL April 29

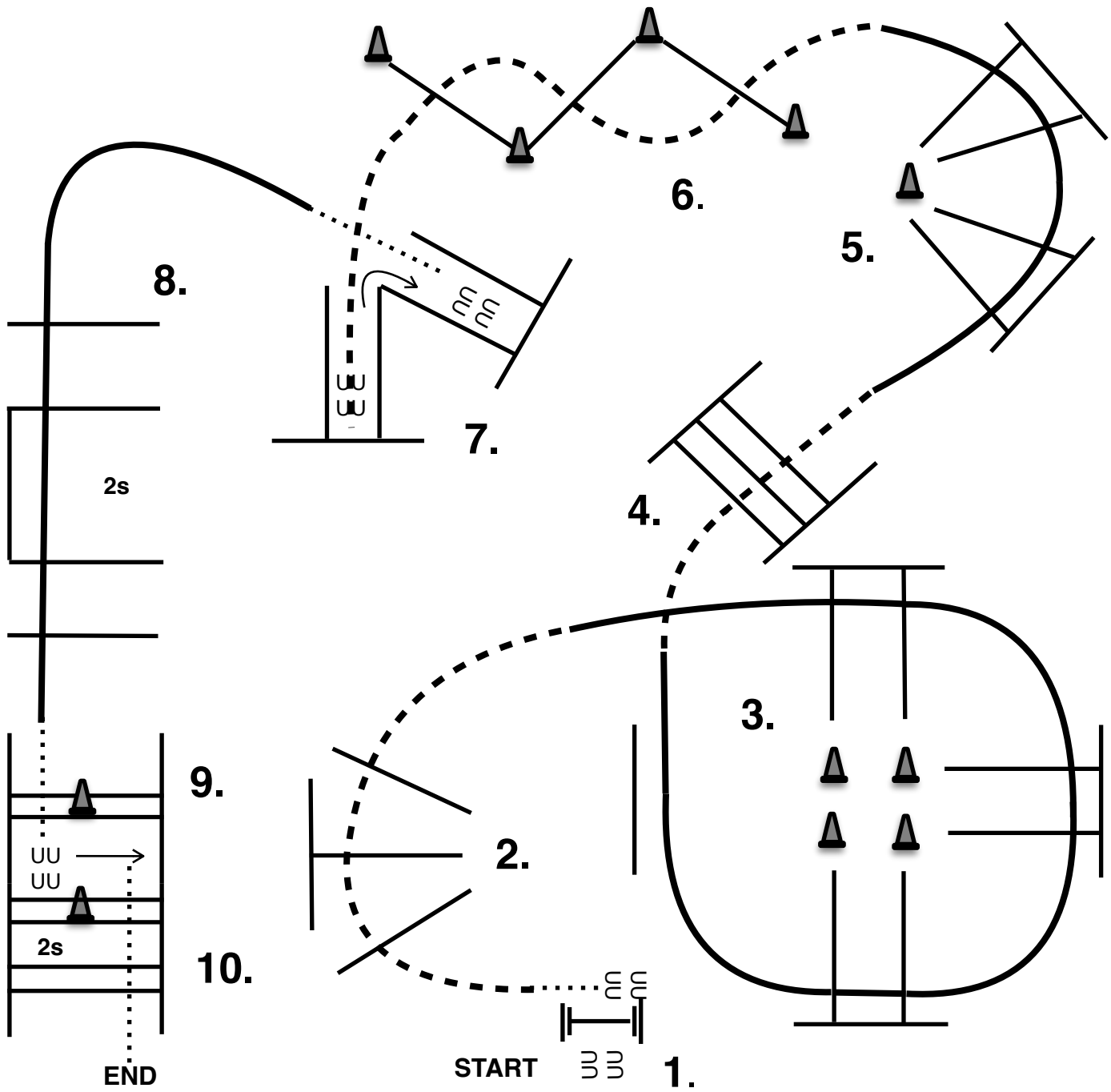

1. Work Left Hand Gate.
2. You may walk forward, Jog over poles.
3. Lope Right Lead over poles.
4. Jog over poles.
5. Lope Left Lead over poles.
6. Jog over poles into the chute.
7. Back around into chute. Walk out of chute.
8. Lope Left Lead over poles.
9. Stop or Walk. Walk over poles. Side pass to the Left.
10. Walk out over poles to End Pattern.



| | |
|------|-------|
| WALK | |
| JOG | ----- |
| LOPE | ————— |

Open, Amateur, Youth TRAIL April 29th

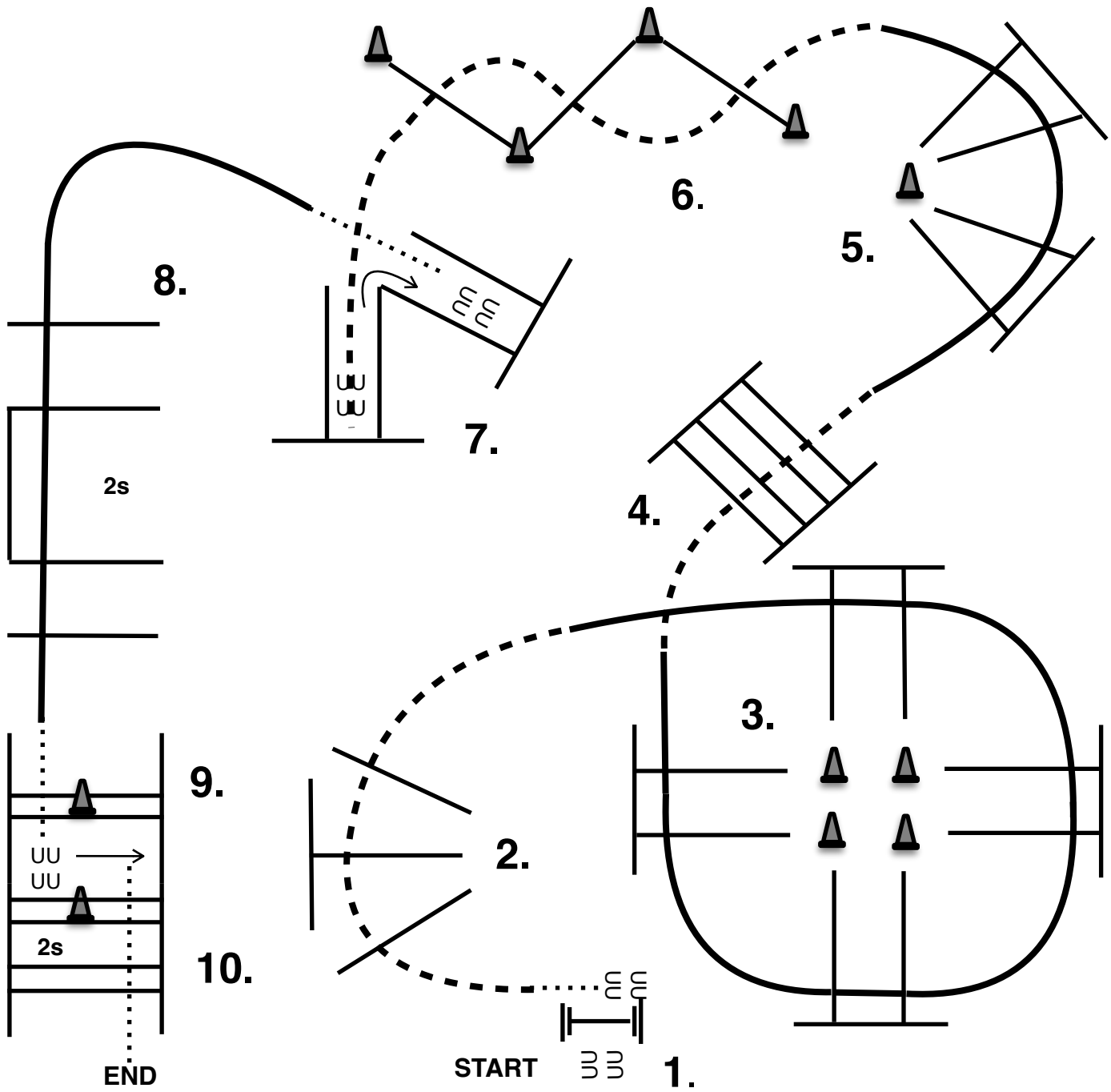

1. Work Left Hand Gate.
2. You may walk forward, Jog over poles.
3. Lope Right Lead over poles.
4. Jog over poles.
5. Lope Left Lead over poles.
6. Jog over poles into the chute.
7. Back around into chute. Walk out of chute.
8. Lope Left Lead over poles.
9. Stop or Walk. Walk over poles. Side pass to the Left.
10. Walk out over poles to End Pattern.



| | |
|------|-----------|
| WALK | |
| JOG | - - - - - |
| LOPE | ————— |

Small Fry, L1 Amateur W/T, L1 Youth W/T TRAIL April 29th

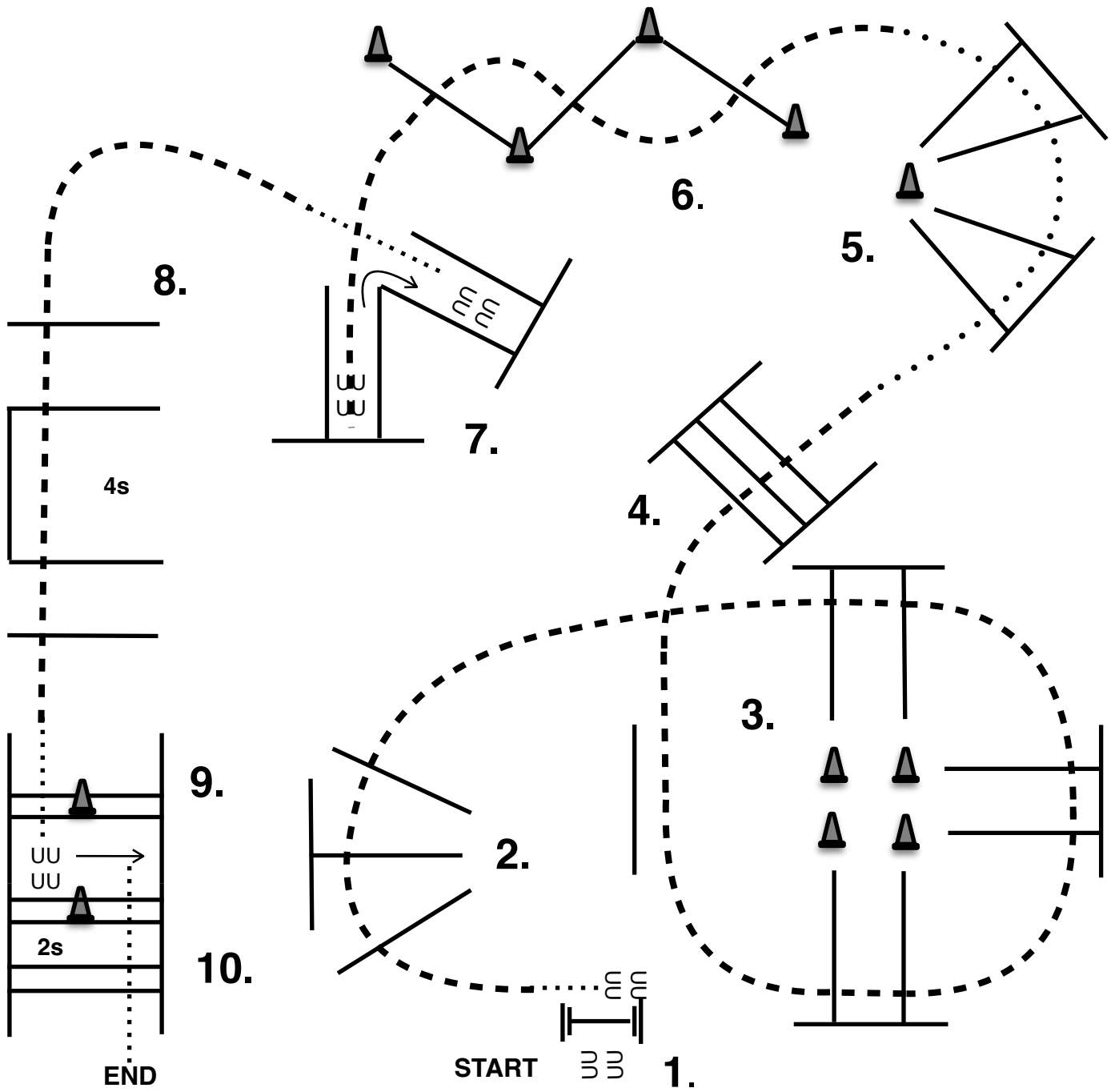

1. Work Left Hand Gate.
2. You may walk forward, Jog over poles.
3. Jog over poles.
4. Jog over poles.
5. Walk over poles.
6. Jog over poles into the chute.
7. Back around into chute. Walk out of chute.
8. Jog over poles.
9. Stop or Walk. Walk over poles. Side pass to the Left.
10. Walk out over poles to End Pattern.



| | |
|------|-------|
| WALK | |
| JOG | ----- |
| LOPE | ————— |

LEVEL I WESTERN RIDING PATTERN 9

LEGEND

| | |
|--------|--------------------|
| | Walk |
| - - - | Jog |
| ———— | Lope |
| ////// | Back |
| ■ | Lead Changing Area |

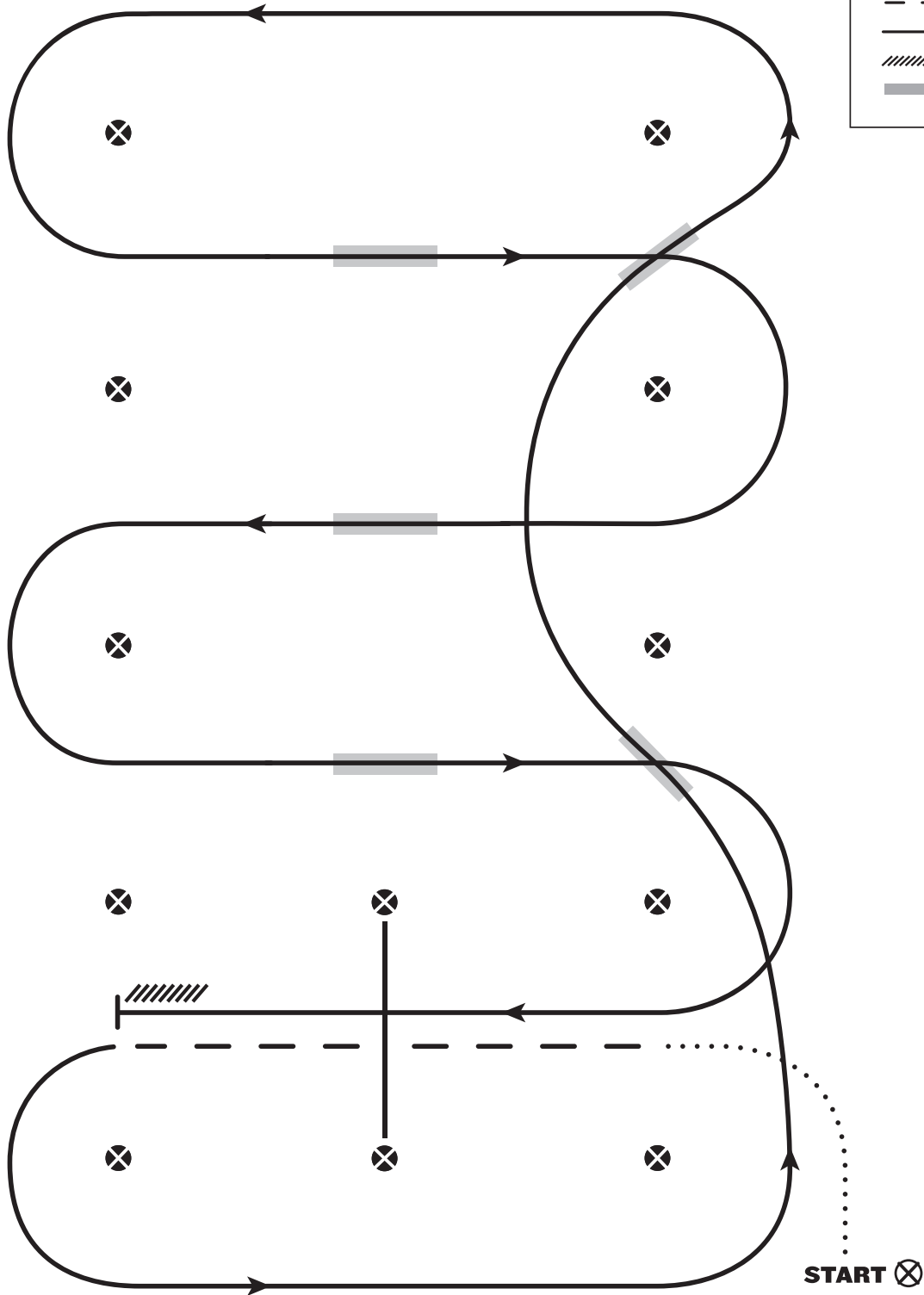

1. Walk at least 15 feet from start cone to the first marker, as drawn, transition to jog, jog over log.
2. Transition to the lope left lead & lope around end
3. First line change
4. Second line change, lope around the end of arena
5. First crossing change
6. Second crossing change
7. Third crossing change
8. Lope over log
9. Lope, stop & back

LEVEL 1 WESTERN RIDING PATTERN 2

LEGEND

| | |
|--------|--------------------|
| | Walk |
| - - - | Jog |
| ———— | Lope |
| ////// | Back |
| ■ | Lead Changing Area |

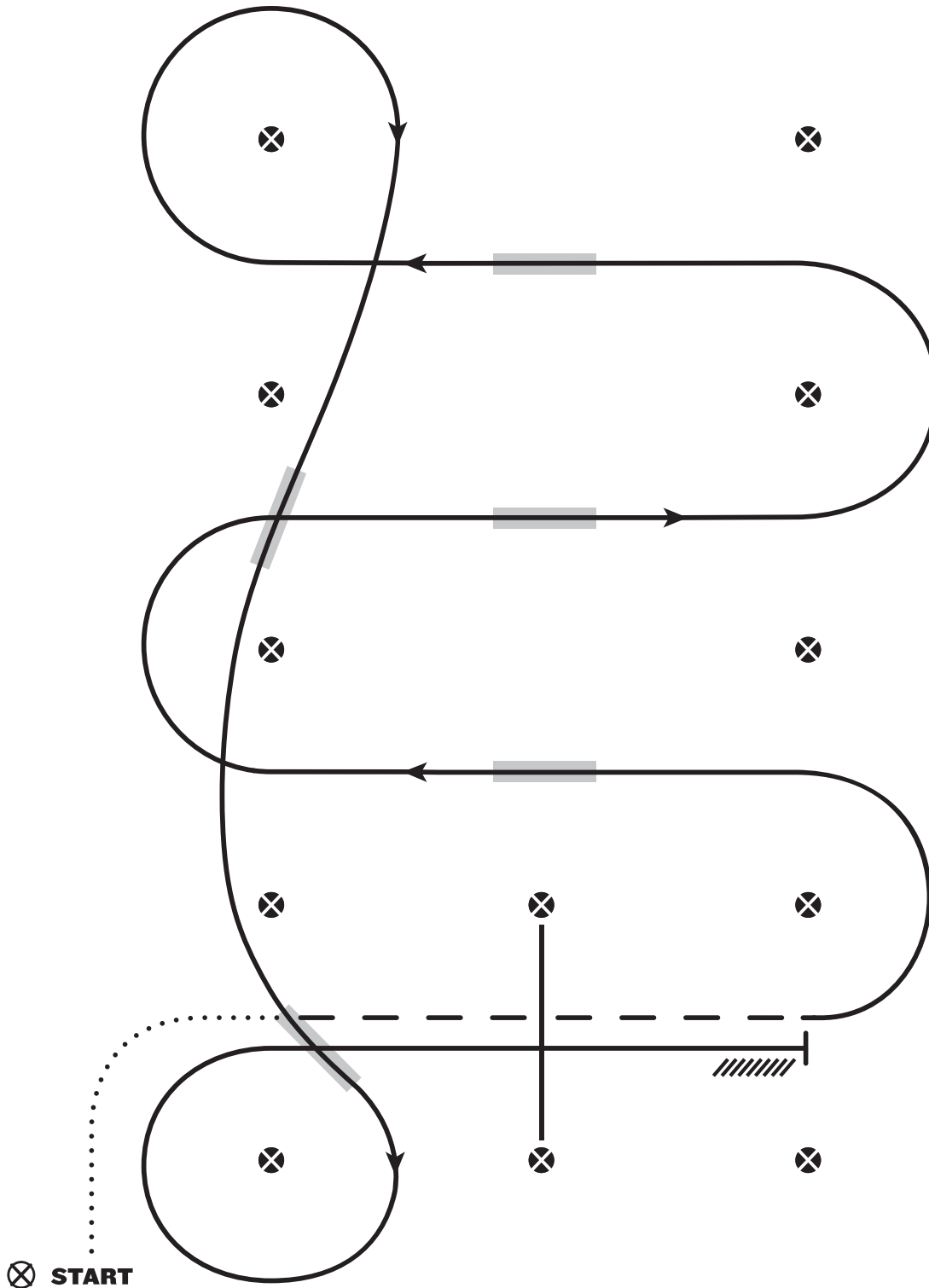

1. Walk at least 15 feet from start cone to the first marker, as drawn, transition to jog, jog over log.
2. Transition to the lope left lead
3. First crossing change
4. Second crossing change
5. Third crossing change
6. Circle & first line change
7. Second line change & circle
8. Lope over log
9. Stop & back

Lucky 7

Hunt Seat Equitation (13/U, 14-18, AM, Select)

Show Date: 4/29-5/1

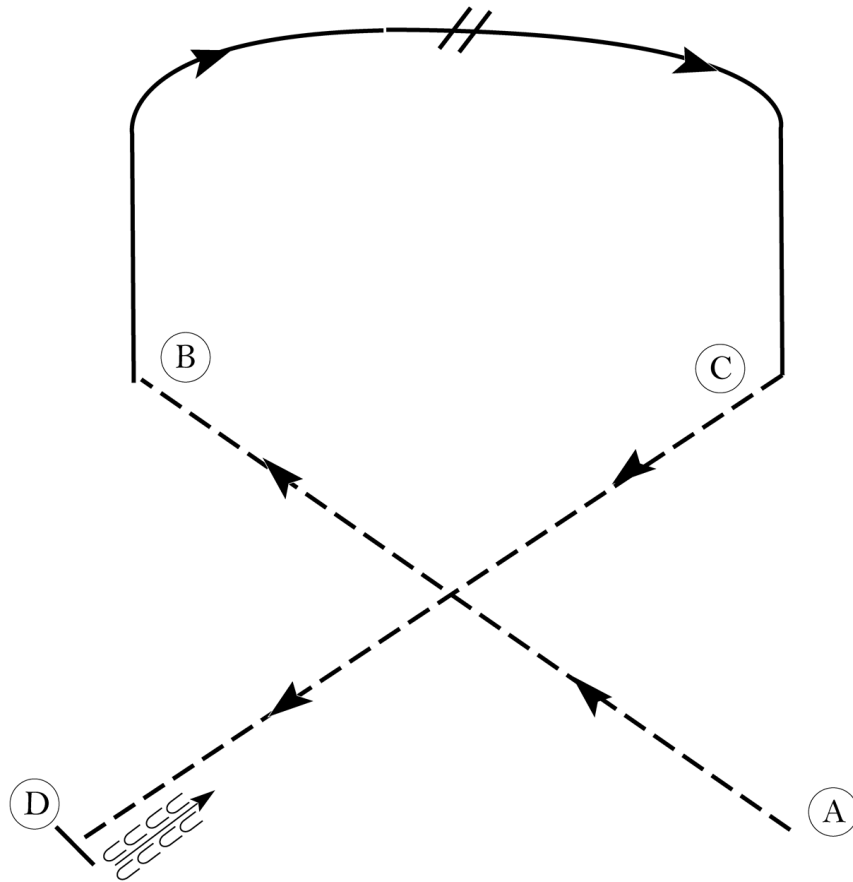

Be ready at A.

1. Sitting trot 1/2 way to B.
2. Posting trot on the left diagonal to B.
3. Canter on the left lead toward C.
4. At the top of the arc, change leads and canter on the right lead to C.
5. Posting trot on the right diagonal 1/2 way to D.
6. Sitting trot to D.
7. Halt at D and back approximately one horse length.

Exit at a sitting trot.

| | |
|---------------|-----------|
| Walk | ----- |
| Trot | - - - - - |
| Extended Trot | — — — — — |
| Canter | — — — — — |
| Leg Yield | |
| Lead Change | — / — |
| Back | ← ← ← ← ← |
| Marker | (B) |
| Sidepass | ← ← ← ← ← |
| Hand Gallop | — — — — — |

[HSE/3-23]

Pattern Provided by:

Judges

Lucky 7

Hunt Seat Equitation (L1 Youth/AM)

Show Date: 4/29-5/1

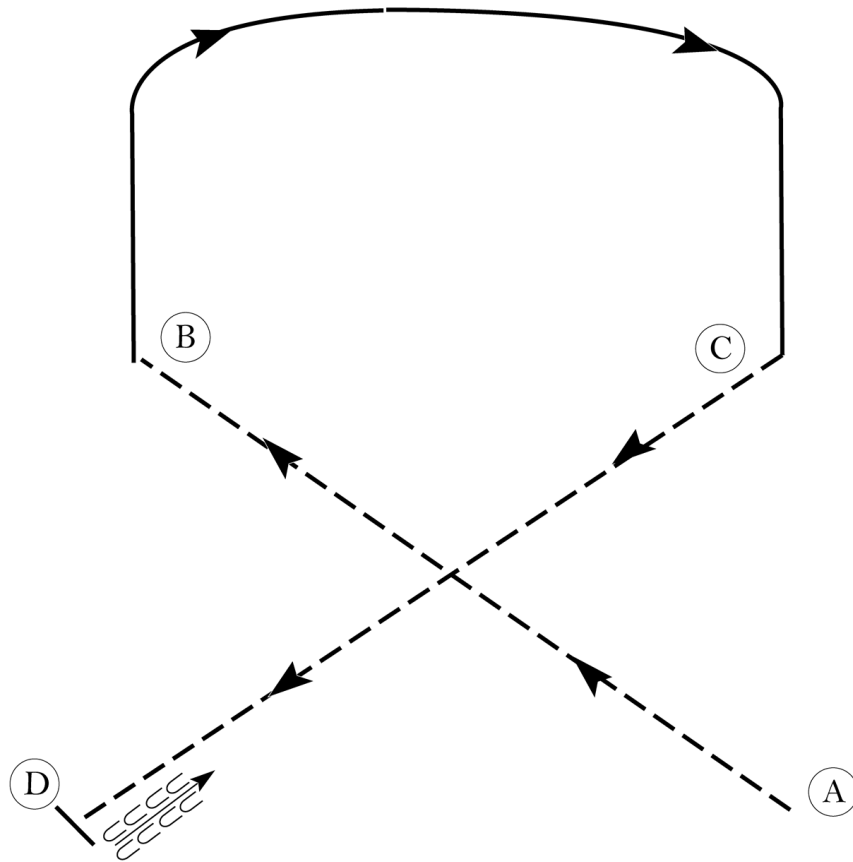

Be ready at A.

1. Posting trot on the left diagonal to B.
2. Canter right lead to C.
3. Posting trot on the right diagonal 1/2 way to D.
4. Sitting trot to D.
5. Halt at D and back approximately one horse length.

Exit at a sitting trot.

| | |
|---------------|-----------|
| Walk | ----- |
| Trot | - - - - - |
| Extended Trot | — — — — — |
| Canter | — — — — — |
| Leg Yield | |
| Lead Change | — / — |
| Back | ← ← ← ← ← |
| Marker | (B) |
| Sidepass | ← ← ← ← ← |
| Hand Gallop | — — — — — |

[HSE/1-23]

Pattern Provided by:

Judges

Lucky 7

Hunt Seat Equitation (L1 WT, Small Fry)

Show Date: 4/29-5/1

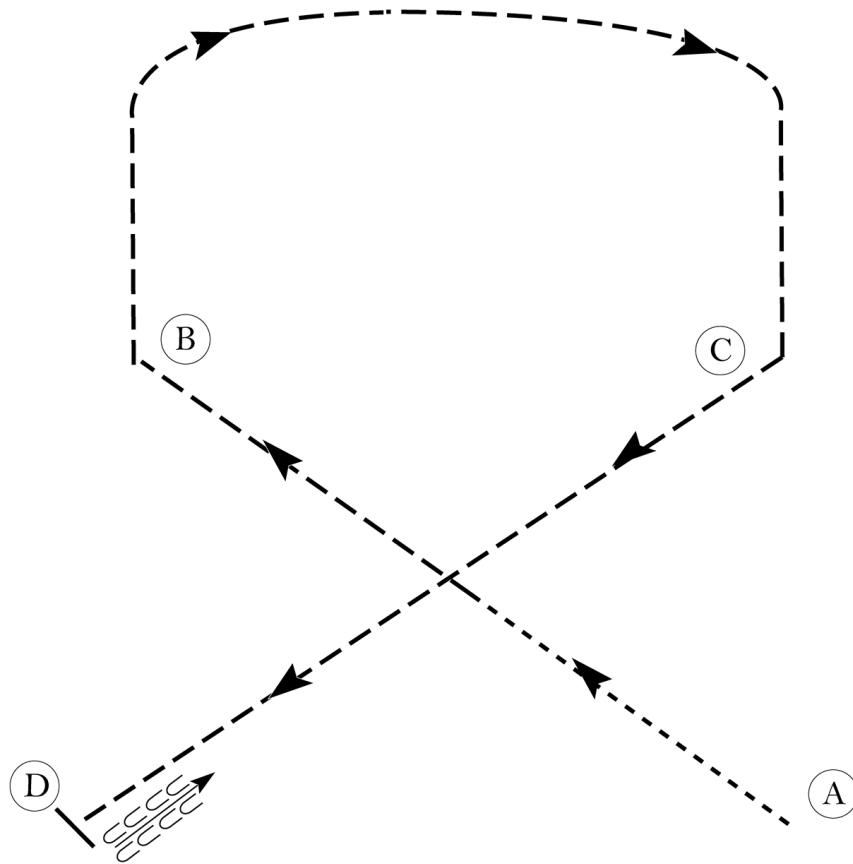

Be ready at A.

1. Walk 1/2 way to B.
2. Posting trot on the left diagonal to B.
3. Sitting trot to C.
4. Posting trot on the right diagonal 1/2 way to D.
5. Sitting trot to D.
6. Halt at D and back approximately one horse length.

Exit at a sitting trot.

| | |
|---------------|-----------|
| Walk | ----- |
| Trot | - - - - - |
| Extended Trot | — — — — — |
| Canter | — — — — — |
| Leg Yield | |
| Lead Change | — / — |
| Back | ← ← ← ← ← |
| Marker | (B) |
| Sidepass | ← ← ← ← ← |
| Hand Gallop | — — — — — |

[HSE/WT-23]

Pattern Provided by:

Judges

ALL REINING PATTERN 14-April 29, 2026

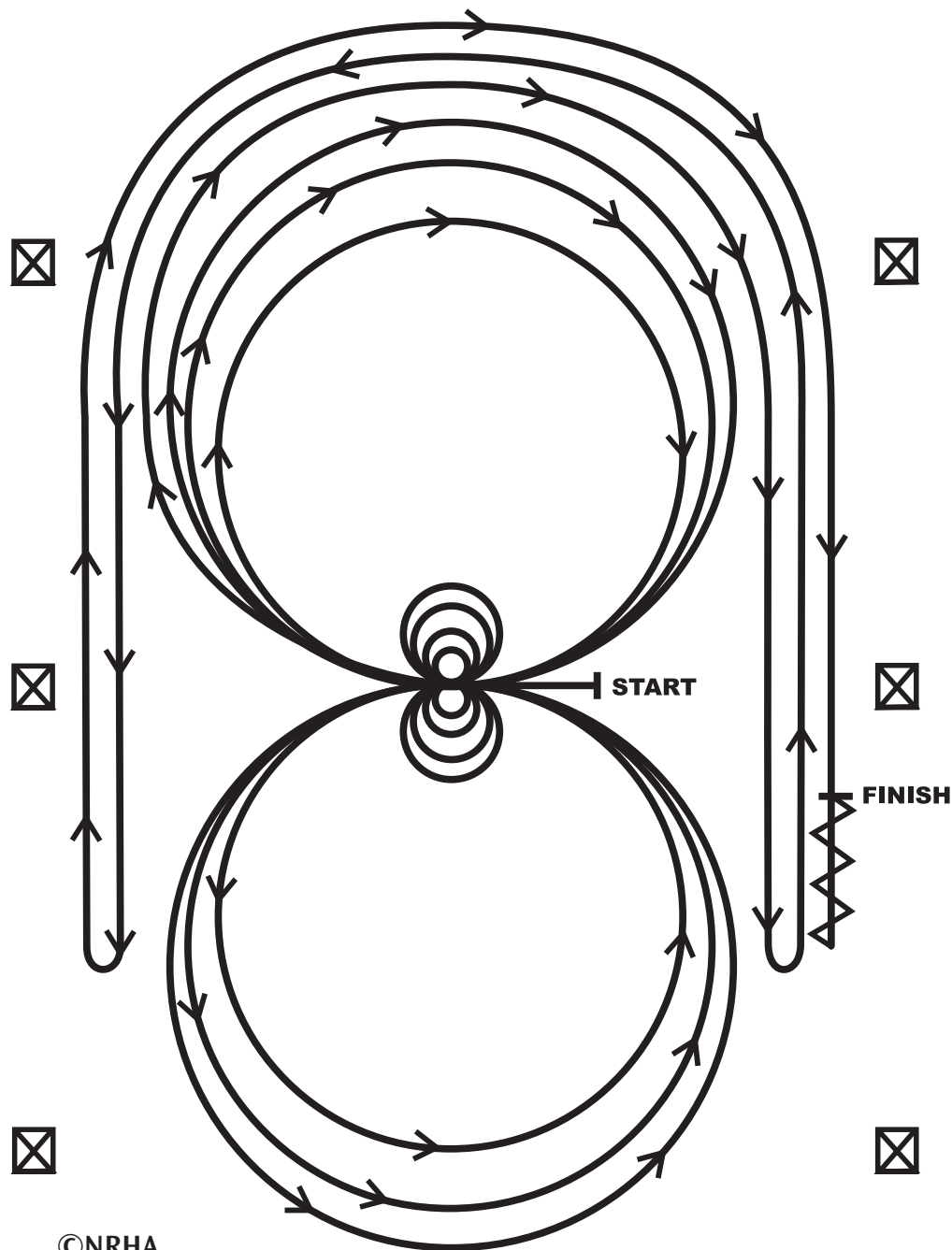

©NRHA

Horses may walk or jog to the center of arena. Horses must walk or stop prior to starting pattern. Beginning at the center of the arena facing the left wall or fence.

1. Complete four spins to the left. Hesitate.
2. Complete four spins to the right. Hesitate.
3. Beginning on the right lead, complete three circles to the right: the first two circles large and fast; the third circle small and slow. Change leads at the center of the arena.
4. Complete three circles to the left: the first two circles large and fast; the third circle small and slow. Change leads at the center of the arena.
5. Begin a large circle to the right but do not close this circle. Run up the right side of the arena past the center marker and do a left rollback at least twenty feet (six meters) from the wall or fence—no hesitation.
6. Continue back around previous circle but do not close this circle. Run up the left side of the arena past the center marker and do a right rollback at least twenty feet (six meters) from the wall or fence—no hesitation.
7. Continue back around previous circle but do not close this circle. Run up the right side of the arena past the center marker and do a sliding stop at least twenty feet (six meters) from the wall or fence. Back up at least ten feet (three meters). Hesitate to demonstrate the completion of the pattern.

AQHA Ranch Trail April 29th

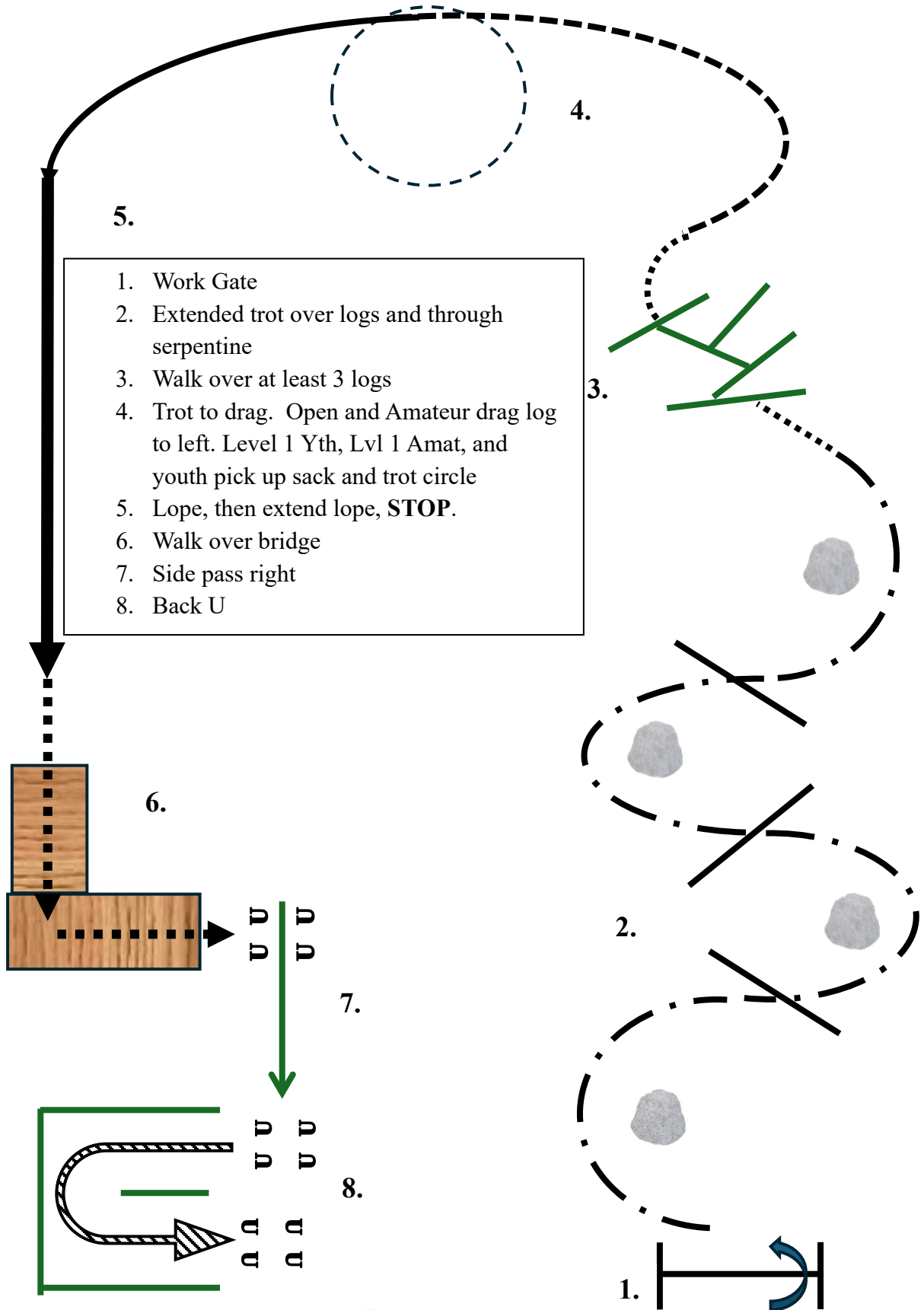

Designed by
Patrick Kayser, 2026

2026 Lucky 7 Fence class courses THURSDAY

Jump each fence from the numbered side.

All Working Hunters 1,2,3,4,5,6,7,8
All Hunter Hacks 4,5

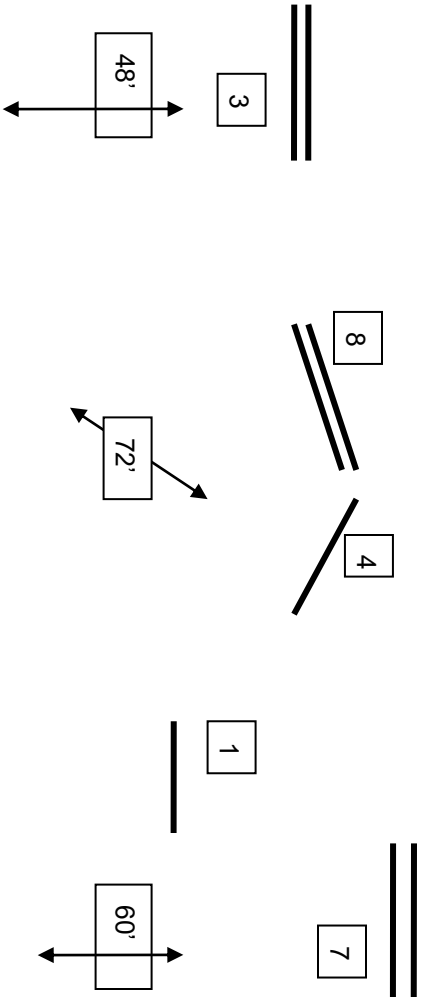
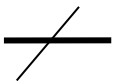

Jump each fence from the numbered side.

All Equitation over Fences 1,2,3,4,5,trot 6,7 DO NOT JUMP 8
Youth, Amateur, All-Age Jumpers 1,2,3,4,5,6,7,8
Jump-off 1,2,6,7

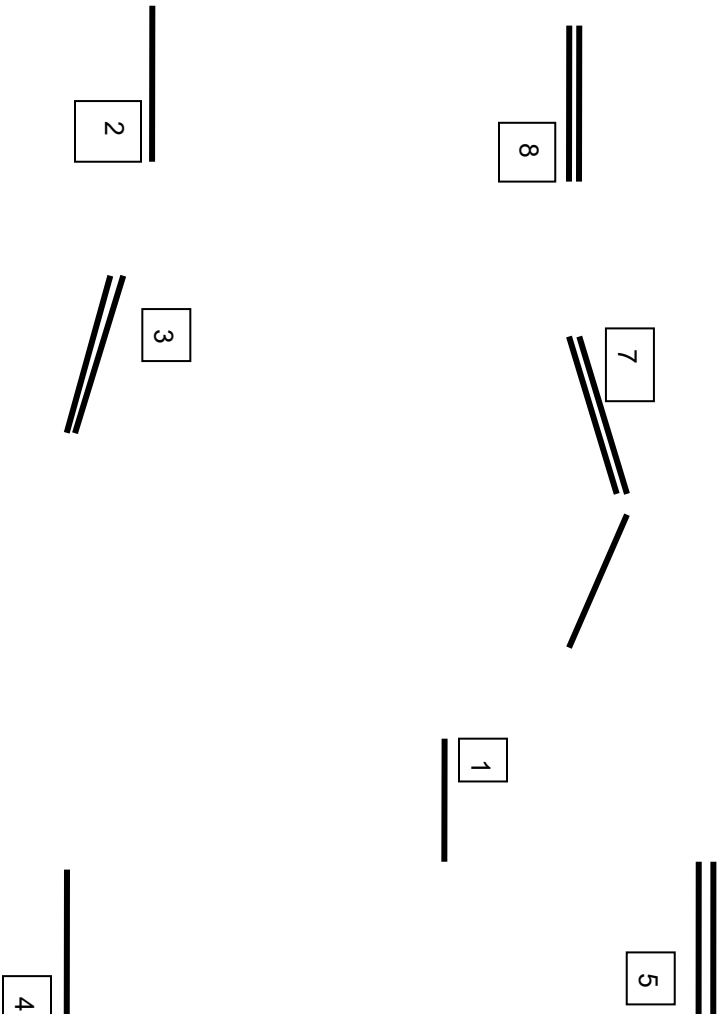
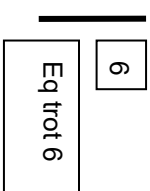

Lucky 7

Western Horsemanship (13/U, 14-18, AM, Select)

Show Date: 4/29-5/1

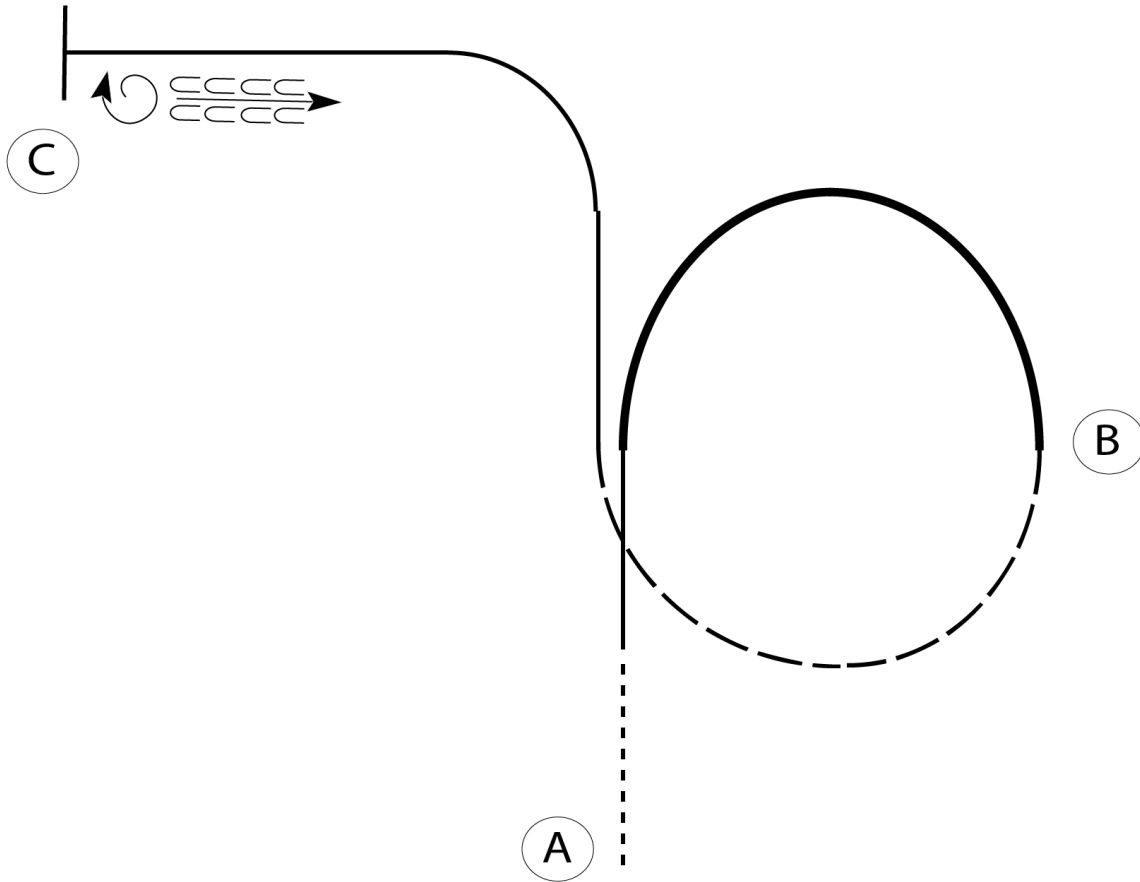

Be ready at A. Not being ready at A is considered LATE.

1. Walk FORWARD approximately 2 horse lengths from A.
2. Lope right lead until even with B.
3. Extend the lope in a half circle until even with B.
4. Extended jog to close the circle.
5. Left lead lope in an arc to C.
6. Stop and perform a 360 degree turn right.
7. Back approximately 5 steps. Pattern is complete.

| | |
|--------------|-----------|
| Walk | ----- |
| Jog | - - - - - |
| Extended Jog | — — — — |
| Lope | ————— |
| Lead Change | |
| Back | |
| Marker | (B) |

[WH/3-121]

Pattern Provided by:

Judges

Lucky 7

Western Horsemanship (L1 Youth/AM)

Show Date: 4/29-5/1

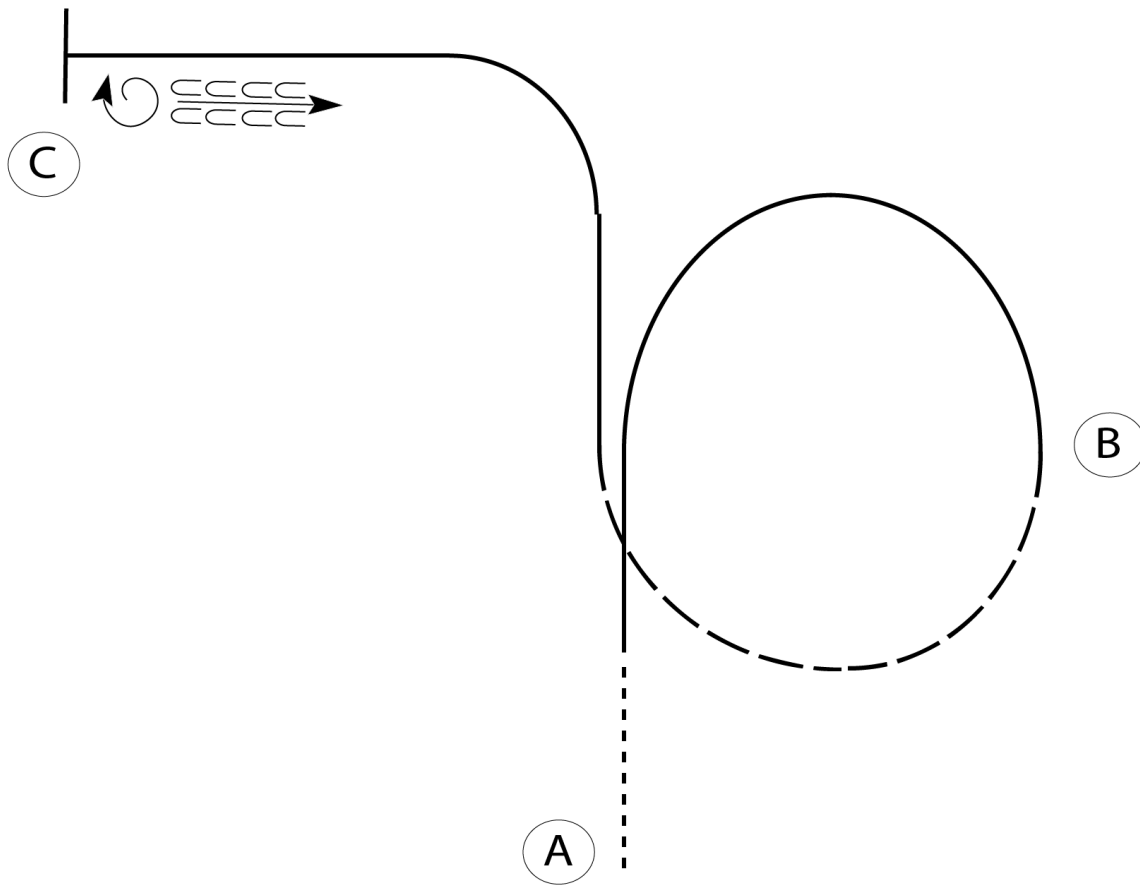

Be ready at A. Not being ready at A is considered LATE.

1. Walk FORWARD approximately 2 horse lengths from A.
2. Lope right lead until even with B.
3. Continue the lope in a half circle until even with B.
4. Extended jog to close the circle.
5. Left lead lope in an arc to C.
6. Stop and perform a 360 degree turn right.
7. Back approximately 5 steps. Pattern is complete.

| | |
|--------------|----------------------|
| Walk | |
| Jog | ----- |
| Extended Jog | ----- |
| Lope | ————— |
| Lead Change | ———/——— |
| Back | ←——— ←——— ←——— |
| Marker | ⊙ B |

[WH/2-121]

Pattern Provided by:

Judges

Lucky 7

Western Horsemanship (L1 WT, Small Fry)

Show Date: 4/29-5/1

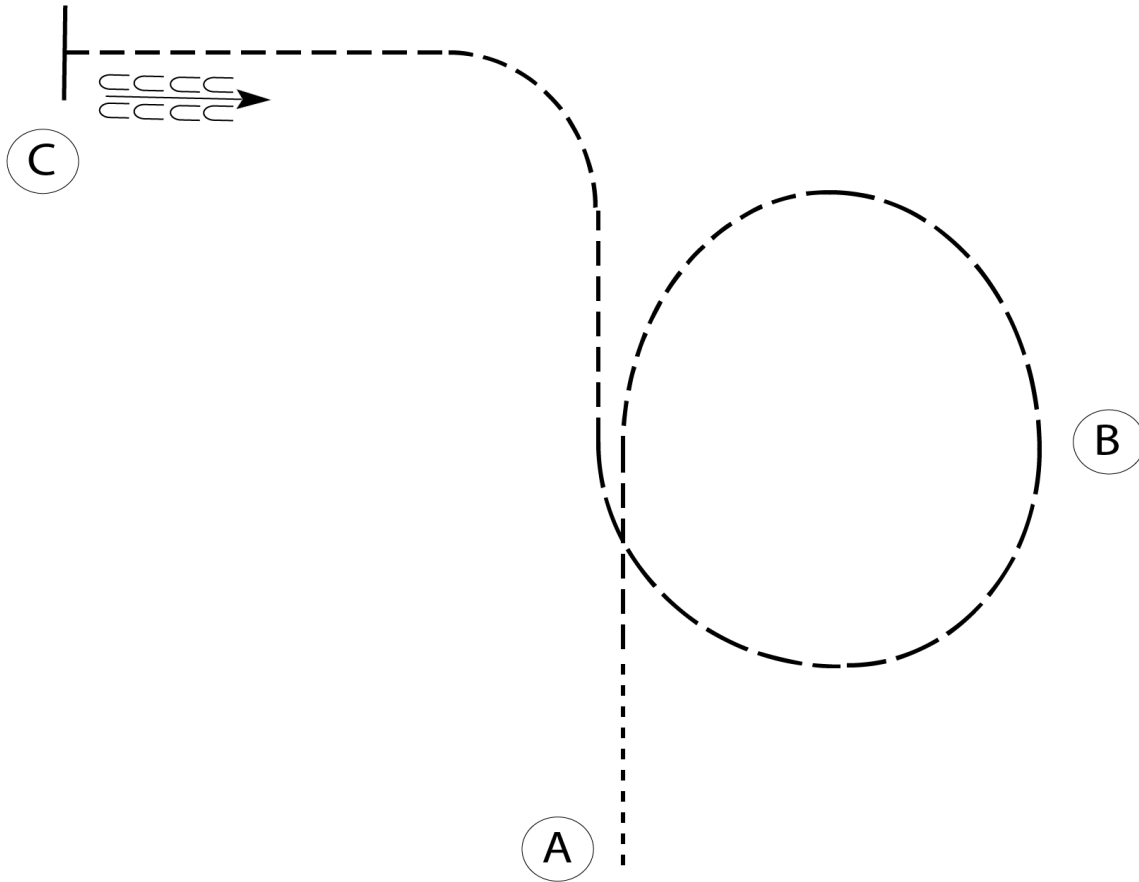

Be ready at A. Not being ready at A is considered LATE.

1. Walk FORWARD approximately 2 horse lengths from A.
2. Jog until even with B.
3. Continue to jog a 1/4 circle.
4. Extended jog 3/4 circle to close the circle.
5. Jog in an arc to C.
6. Stop and Back approximately 5 steps.
Pattern is complete.

| | |
|--------------|-----------|
| Walk | ----- |
| Jog | - - - - - |
| Extended Jog | - - - - - |
| Lope | |
| Lead Change | ↗ ↘ |
| Back | ← ← ← ← ← |
| Marker | ⊙ B |

[WH/WT-121]

Pattern Provided by:

Judges

RANCH RIDING - PATTERN 5

LEGEND

| | |
|---------|---------------|
| | Walk |
| | Extended Walk |
| - - - | Trot |
| - - - - | Extended Trot |
| — — — | Lope |
| — — — — | Extended Lope |
| //// | Back |
| // | Lead Change |

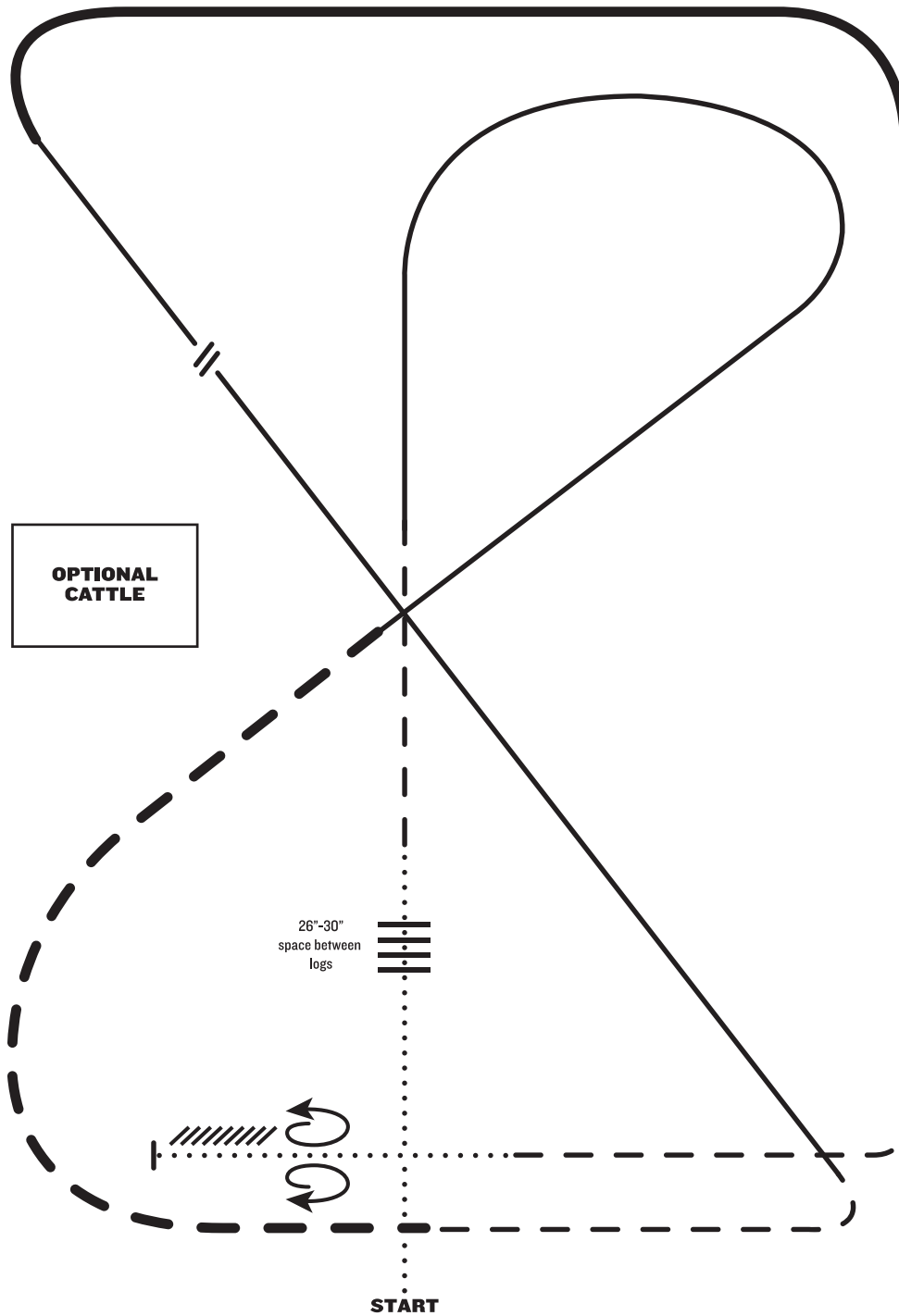

**OPTIONAL
CATTLE**

1. Walk
2. Walk over logs
3. Trot
4. Lope right lead
5. Extended trot
6. Trot
7. Lope left lead
8. Change leads (simple or flying)
9. Extended lope right lead
10. Collect lope
11. Trot
12. Walk
13. Stop and back
14. 360° turn each direction (either direction 1st) (L-R or R-L)

Note: The drawn description of this pattern is only intended for the general depiction of the pattern. Exhibitors should utilize the arena space to best exhibit their horses.

SMALL FRY RANCH RIDING - PATTERN 1

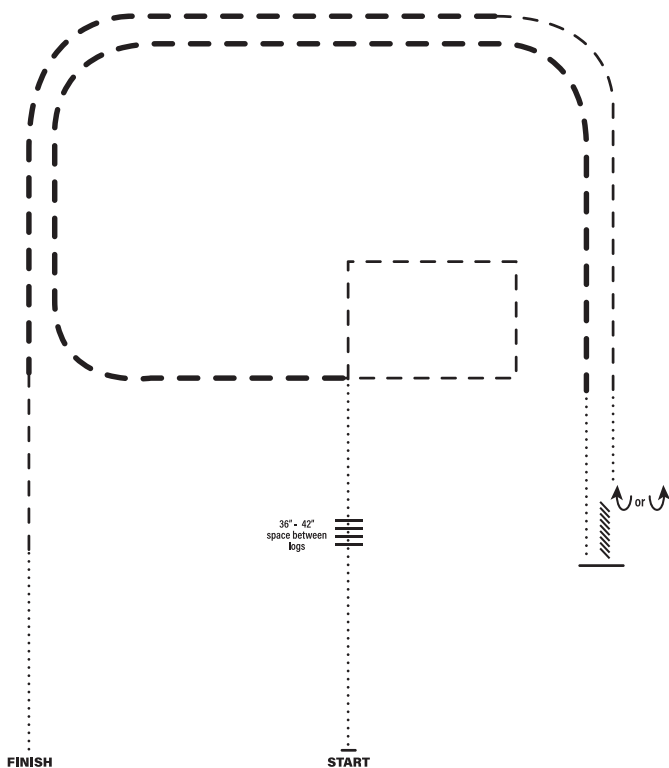

LEGEND

| | |
|---------|---------------|
| | Walk |
| | Extended Walk |
| - - - | Trot |
| - - - - | Extended Trot |
| — — — | Lope |
| — — — — | Extended Lope |
| //// | Back |
| \\ | Lead Change |

1. Walk over logs
2. Trot square at center
3. Extended trot at midline
4. Walk
5. Stop and back approximately 2 horse lengths
6. 180° (1/2) turn either direction
7. Walk
8. Trot
9. Extended trot
10. Collect to a trot
11. Walk

Note: The drawn description of this pattern is only intended for the general depiction of the pattern. Exhibitors should utilize the arena space to best exhibit their horses.

Lucky 7

Showmanship (13/U, 14-18, AM, Select)

Show Date: 4/29-5/1

w w w . H o r s e S h o w P a t t e r n s . c o m

w w w . H o r s e S h o w P a t t e r n s . c o m

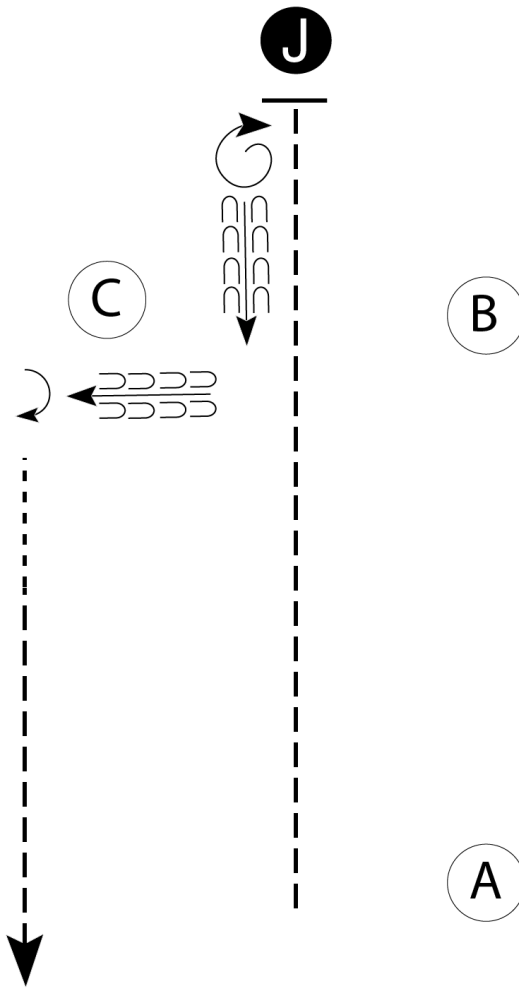

Be ready at A.

1. Trot to Judge.
2. Perform a 360 degree turn.
3. Set up for Inspection.
4. When dismissed, back L.
5. Perform a 90 degree turn.
6. Walk 2 horse lengths then trot to exit.
7. Pattern is complete once you trot past start cone.

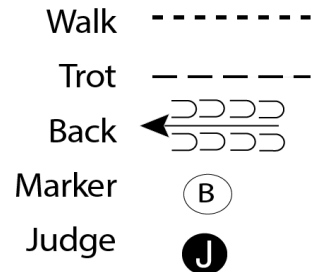

[S/1]

Pattern Provided by:

Judges

Lucky 7

Showmanship (L1 Youth/AM)

Show Date: 4/29-5/1

w w w . H o r s e S h o w P a t t e r n s . c o m

w w w . H o r s e S h o w P a t t e r n s . c o m

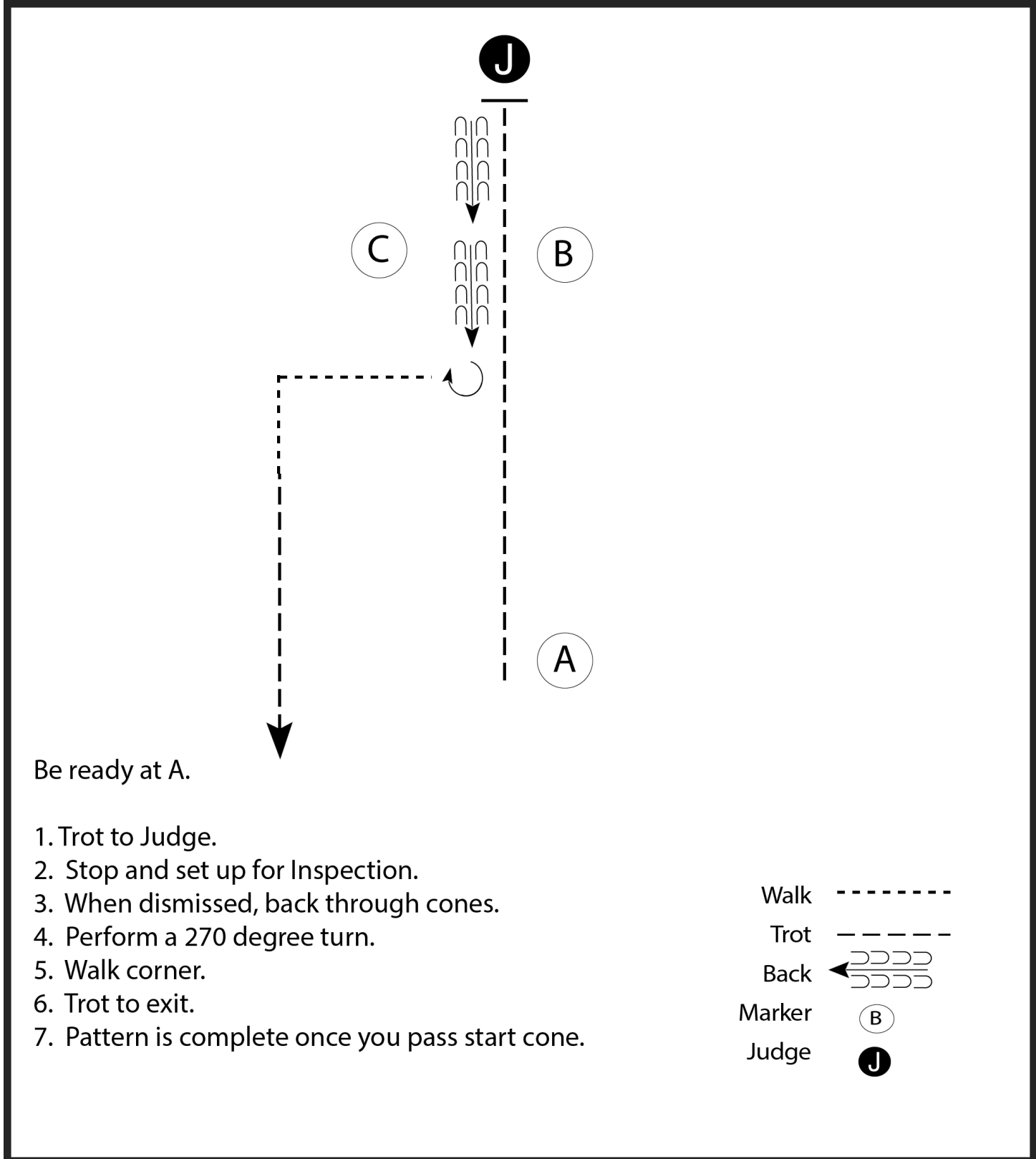

Be ready at A.

1. Trot to Judge.
2. Stop and set up for Inspection.
3. When dismissed, back through cones.
4. Perform a 270 degree turn.
5. Walk corner.
6. Trot to exit.
7. Pattern is complete once you pass start cone.

- Walk -----
- Trot - - - - -
- Back ←
- Marker ○ B
- Judge ● J

[S/3]

Pattern Provided by:

Judges

Level 1 RANCH TRAIL May 1st

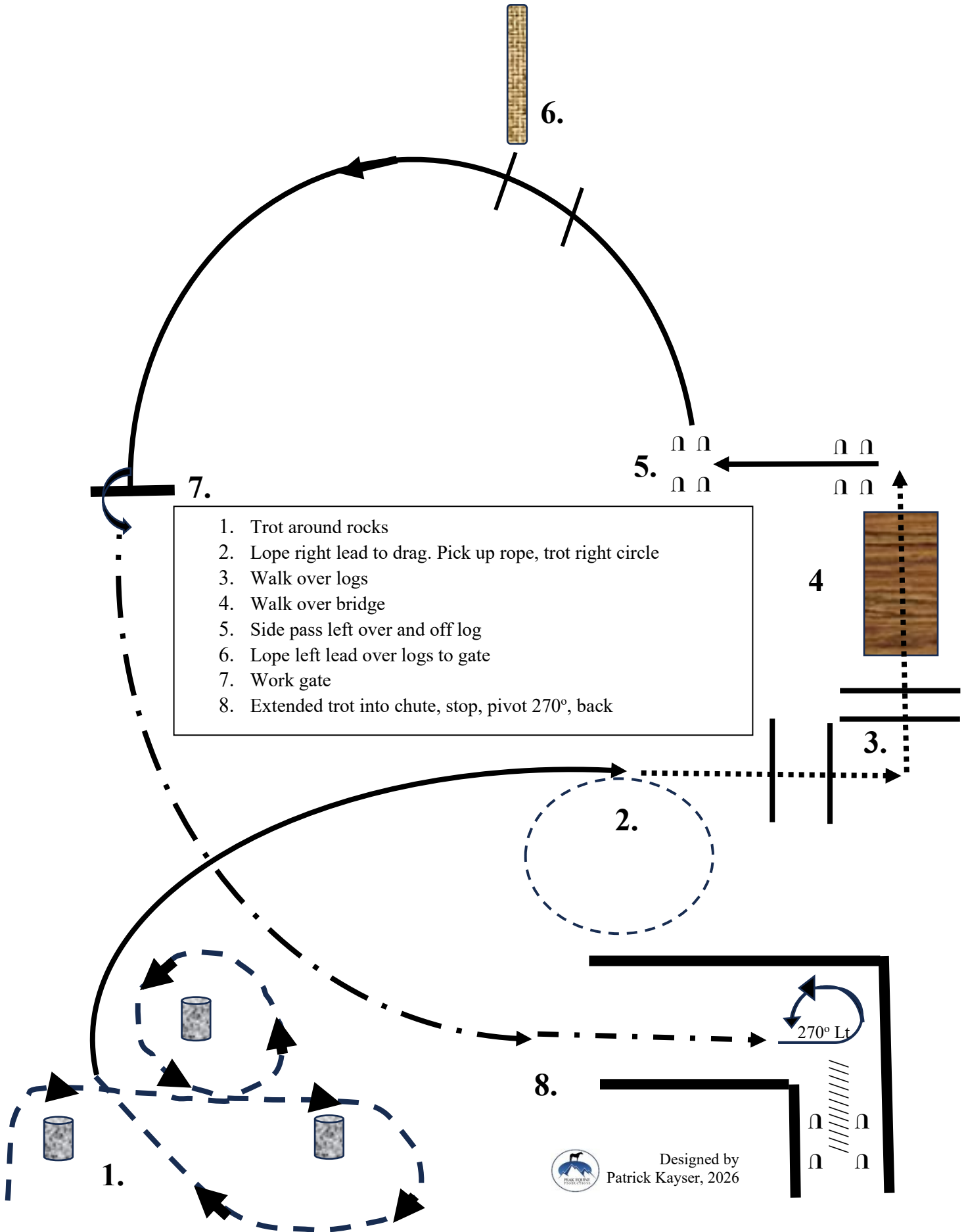

1. Trot around rocks
2. Lope right lead to drag. Pick up rope, trot right circle
3. Walk over logs
4. Walk over bridge
5. Side pass left over and off log
6. Lope left lead over logs to gate
7. Work gate
8. Extended trot into chute, stop, pivot 270°, back



Designed by
Patrick Kayser, 2026

OPEN, AMATEUR, YOUTH RANCH TRAIL May 1st

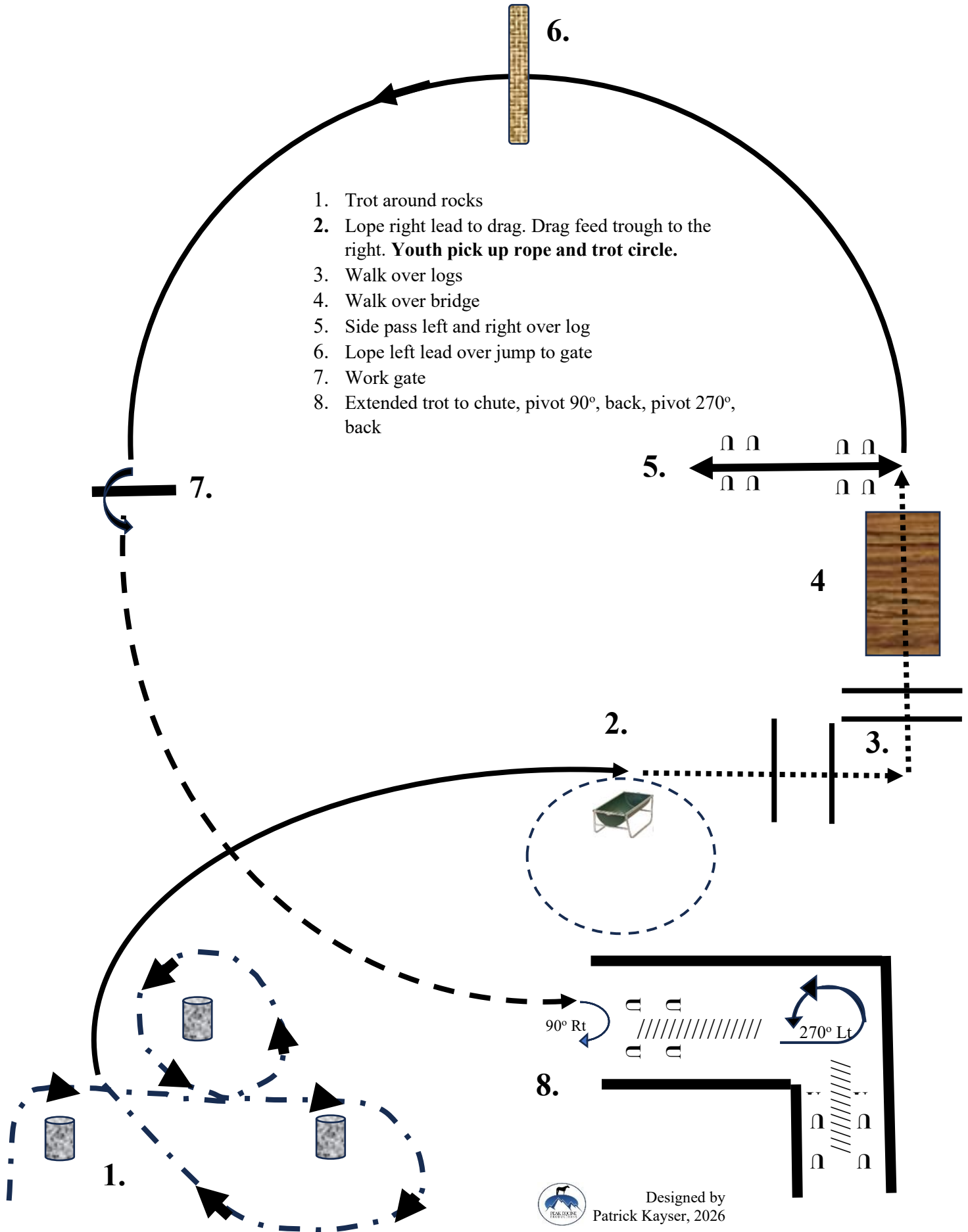

Designed by
Patrick Kayser, 2026

ENGLISH VERSATILITY

PATTERN #3

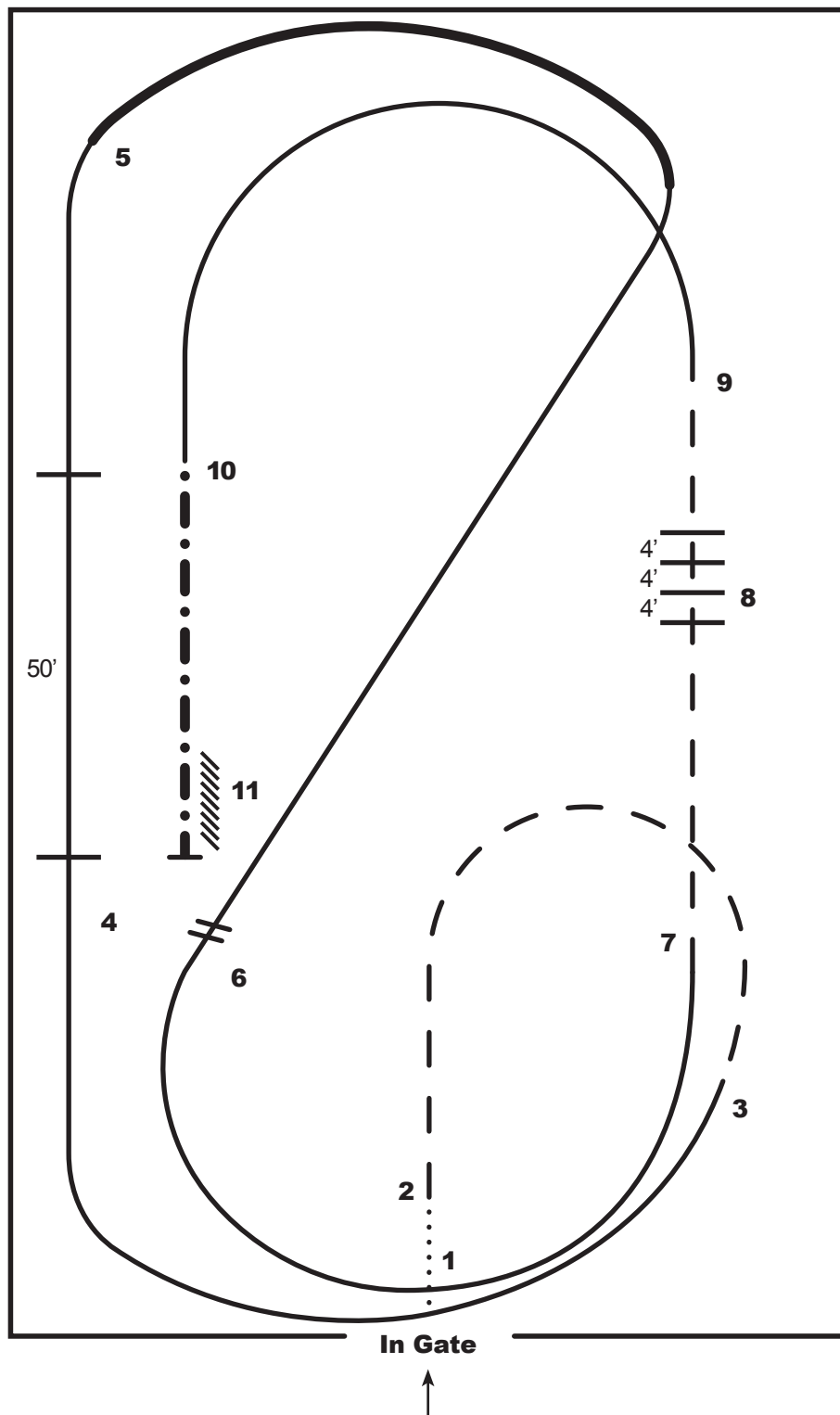

1. Forward walk from gate
2. Trot left diagonal, half circle
3. Canter right lead
4. Canter poles
5. Hand gallop through turn
6. Canter across the diagonal and change leads (simple or flying)
7. Trot right diagonal
8. Trot poles
9. Canter left lead
10. Extended sitting trot
11. Halt and back; exit ring on a loose rein

ENGLISH VERSATILITY

PATTERN #4

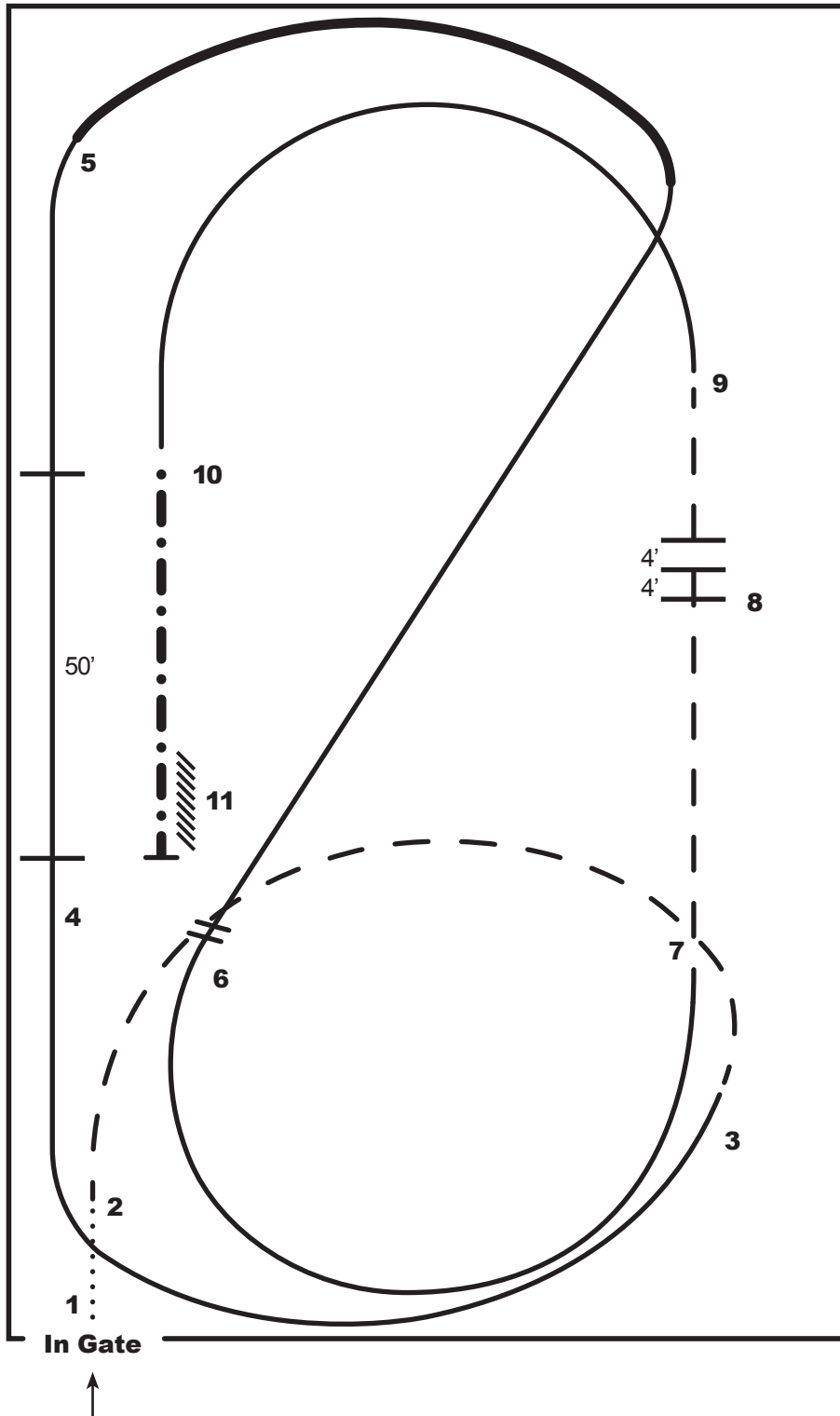

1. Forward walk from gate
2. Trot left diagonal, circle
3. Canter right lead
4. Canter poles
5. Hand gallop through turn
6. Canter across the diagonal and change leads (simple or flying)
7. Trot right diagonal
8. Trot poles
9. Canter left lead
10. Extended sitting trot
11. Halt and back; exit ring on a loose rein

L1, L1 Youth, L1 Amateur, Junior TRAIL May 2nd

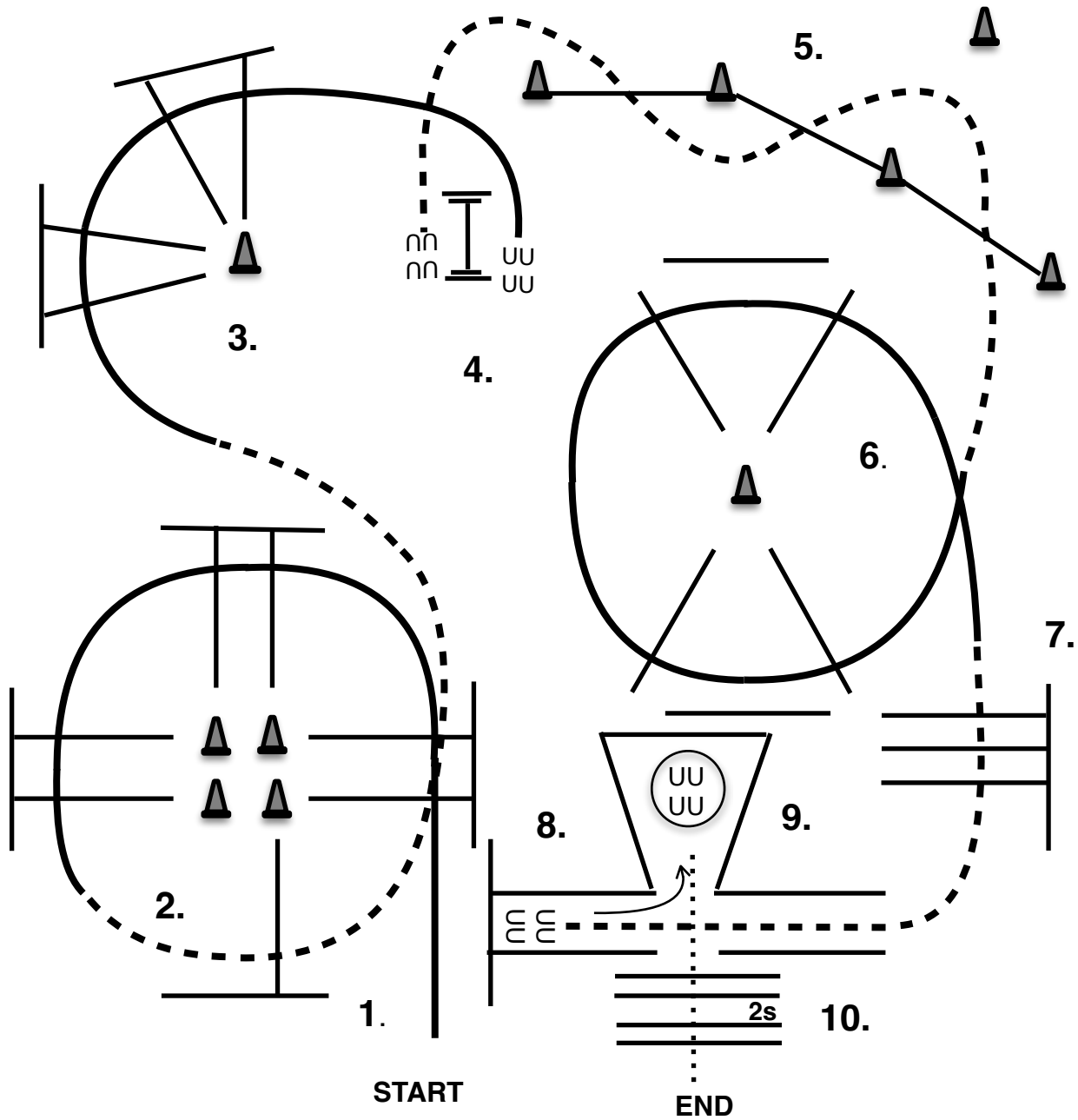

1. Lope Left Lead over poles.
2. Jog over poles.
3. Lope on Right Lead over poles to the Gate.
4. Work Right Hand Gate.
5. Jog over poles as shown.
6. Lope Right Lead over poles.
7. Jog over poles into Chute.
8. Back around into Box.
9. Execute 360 turn either direction.
10. Walk out over poles to End Pattern.



| | |
|------|---------|
| WALK | |
| JOG | - - - - |
| LOPE | ———— |

Youth, Select, Amateur, Senior TRAIL, May 2

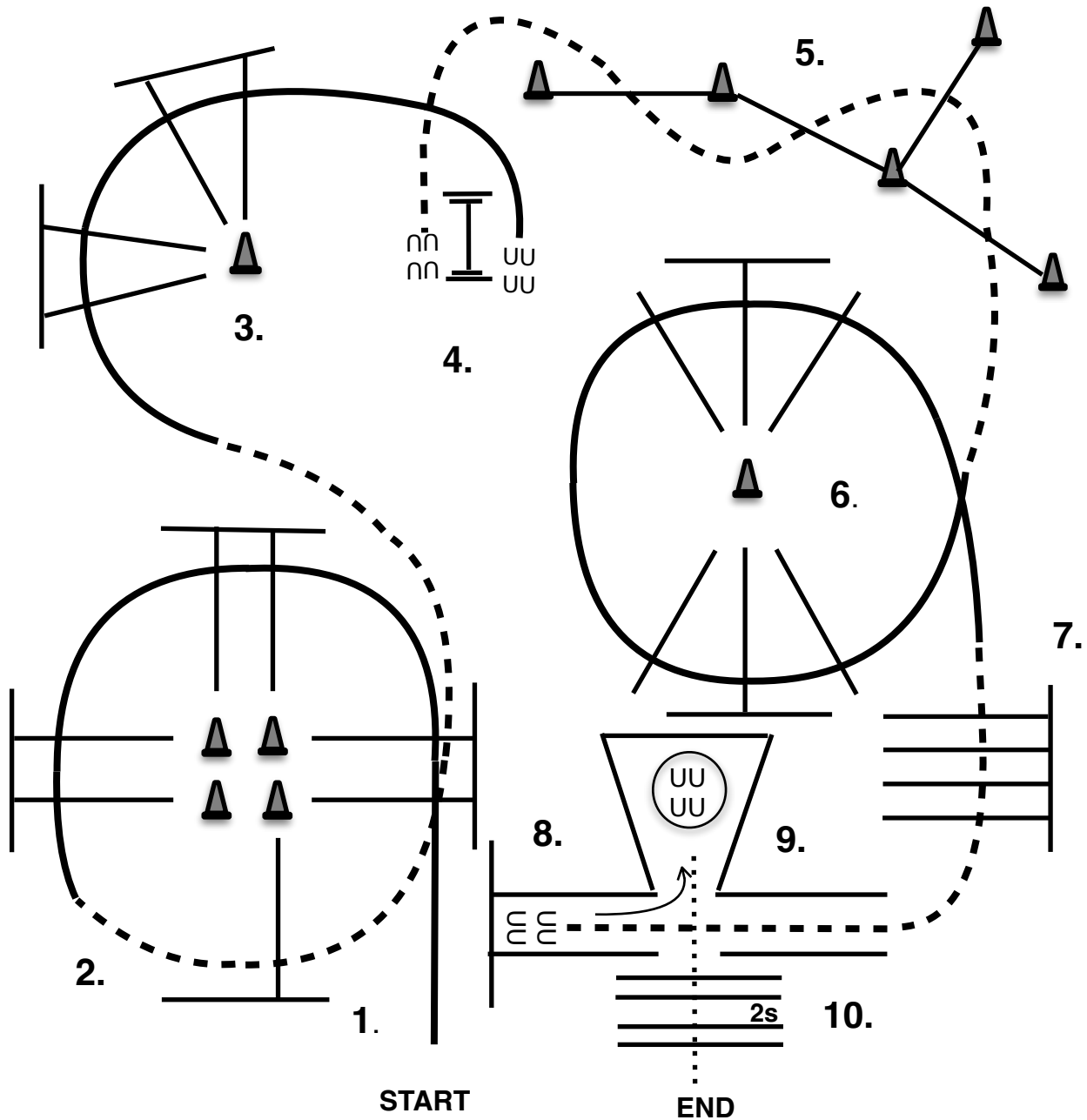

1. Lope Left Lead over poles.
2. Jog over poles.
3. Lope on Right Lead over poles to the Gate.
4. Work Right Hand Gate.
5. Jog over poles as shown.
6. Lope Right Lead over poles.
7. Jog over poles into Chute.
8. Back around into Box.
9. Execute 360 turn either direction.
10. Walk out over poles to End Pattern.



| | |
|------|---------|
| WALK | |
| JOG | - - - - |
| LOPE | _____ |

Small Fry, L1 Youth W/T, L1 Amateur W/T TRAIL May 2

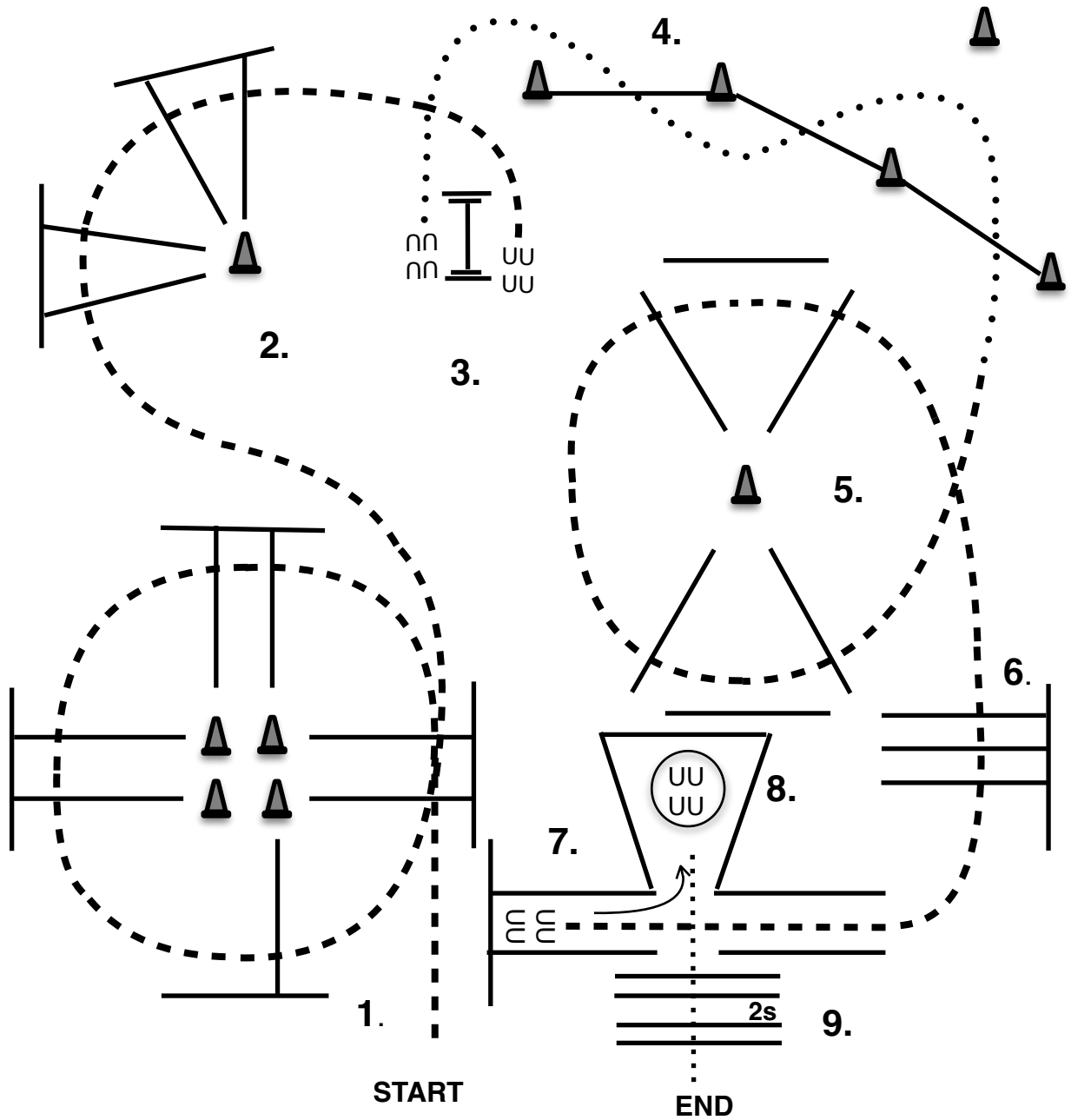

1. Jog over poles.
2. Jog over poles to the Gate.
3. Work Right Hand Gate.
4. Walk over poles as shown.
5. Jog over poles.
6. Jog over poles into Chute.
7. Back around into Box.
8. Execute 360 turn either direction.
9. Walk out over poles to End Pattern.



| | |
|------|---------|
| WALK | |
| JOG | - - - - |
| LOPE | ———— |

WESTERN RIDING - PATTERN 2

LEGEND

| | |
|--------|--------------------|
| | Walk |
| - - - | Jog |
| ———— | Lope |
| ////// | Back |
| ■ | Lead Changing Area |

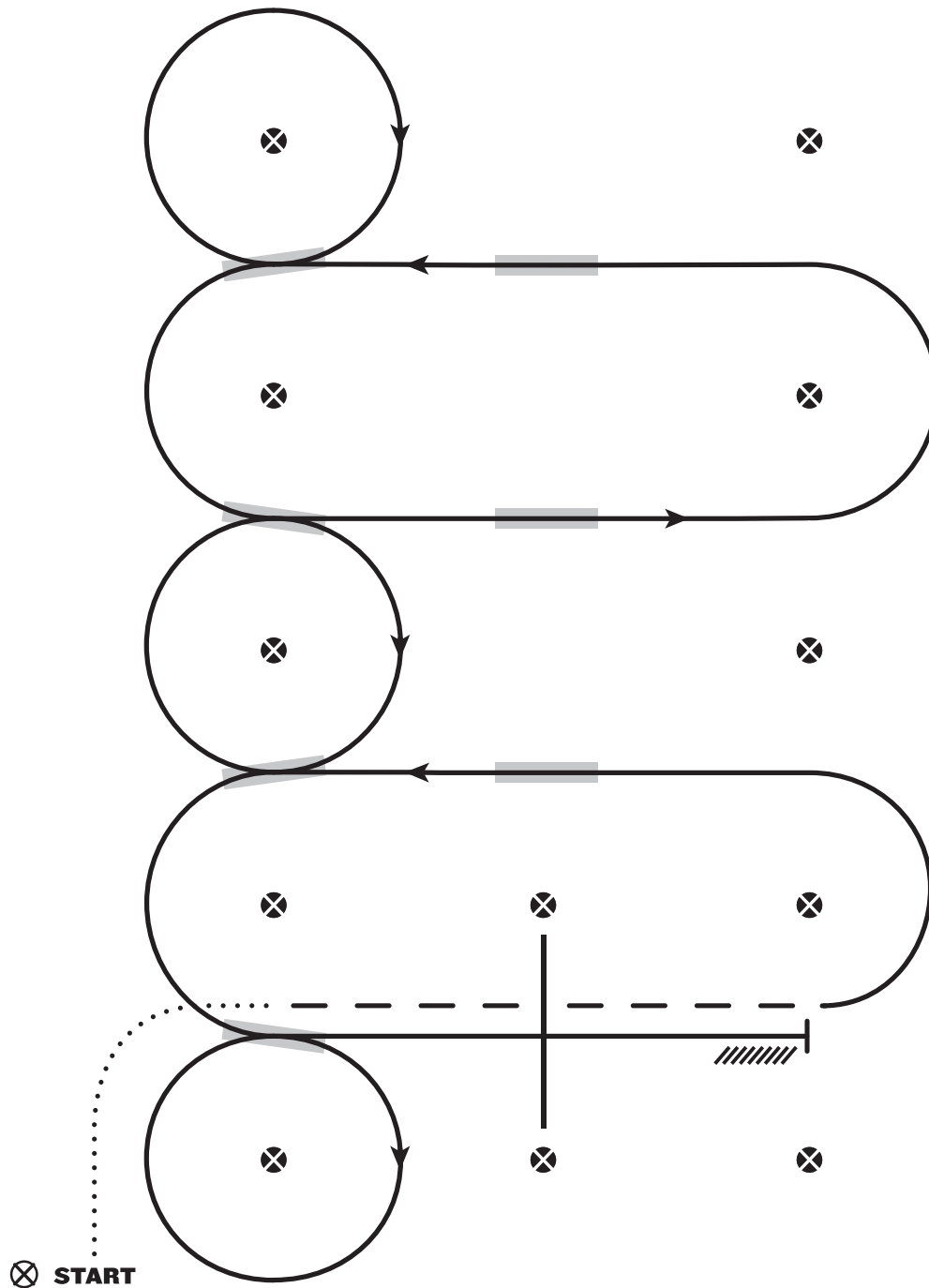

1. Walk at least 15 feet from start cone to the first marker, as drawn, transition to jog, jog over log.
2. Transition to the lope left lead
3. First crossing change
4. Second crossing change
5. Third crossing change
6. Circle & first line change
7. Second line change
8. Third line change
9. Fourth line change & circle
10. Lope over log
11. Lope, stop & back

Lucky 7 Classic

Hunt Seat Equitation (All Walk Trot)

Show Date: 04-29-2026

w w w . H o r s e S h o w P a t t e r n s . c o m

w w w . H o r s e S h o w P a t t e r n s . c o m

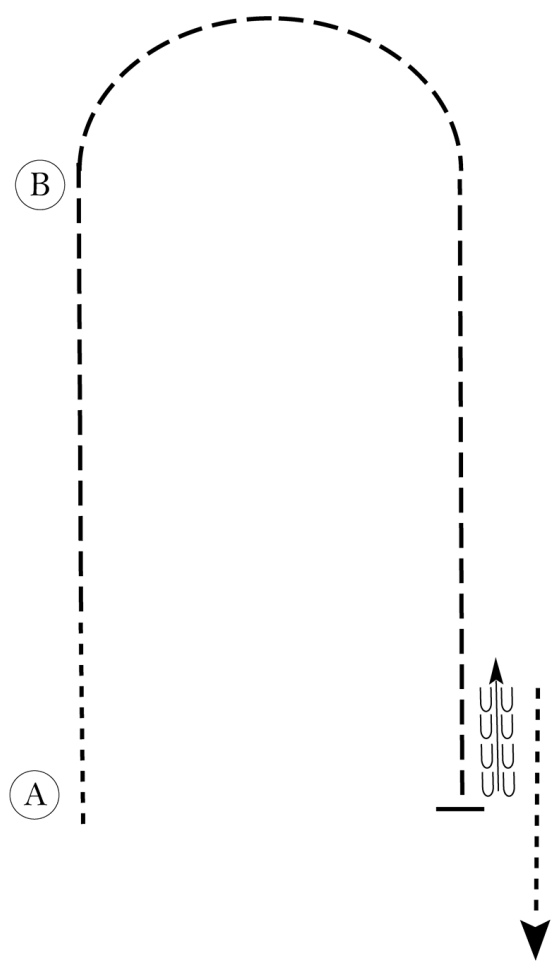

Be ready at A.

1. Walk approximately 2 horse lengths.
2. Posting trot on the left diagonal to B.
3. Sitting trot in a half circle until even with B.
4. Posting trot on the right diagonal until even with A.
5. Halt and back approximately one horse length.
6. Exit pattern at a walk.

Follow the instructions of your ring steward.

| | |
|---------------|-----------|
| Walk | ----- |
| Trot | - - - - - |
| Extended Trot | ----- |
| Canter | ————— |
| Leg Yield | |
| Lead Change | —/— |
| Back | ←←←←← |
| Marker | ⊙ |
| Sidepass | ←-----→ |
| Hand Gallop | ————— |

[HSE/WT-56]

Pattern Provided by:
Judges

Lucky 7 Classic

Hunt Seat Equitation (Youth, Amateur, Select)

Show Date: 04-29-2026

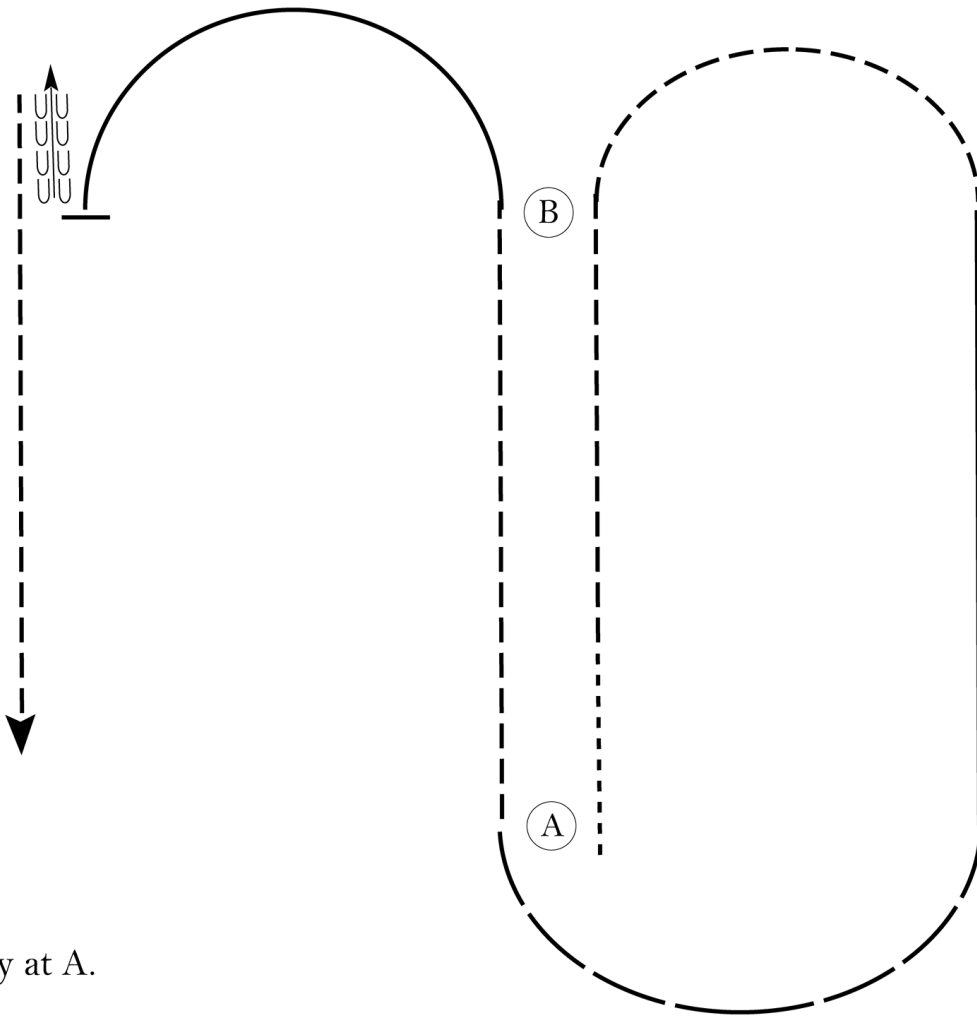

Be ready at A.

1. Walk approximately 2 horse lengths.
2. Posting trot on the left diagonal to B and in a half circle until even with B.
3. Canter on the right lead until even with A.
4. Hand gallop a half circle to A.
5. Posting trot on the right diagonal to B.
6. Left lead canter in a half circle until even with B.
7. Halt and back approximately one horse length.
8. Exit pattern at a sitting trot.

Follow the instructions of your ring steward.

| | |
|---------------|-----------|
| Walk | ----- |
| Trot | - - - - - |
| Extended Trot | ----- |
| Canter | ----- |
| Leg Yield | |
| Lead Change | ↙ ↘ |
| Back | ← ← ← ← ← |
| Marker | (B) |
| Sidepass | ← ← ← ← ← |
| Hand Gallop | ----- |

[HSE/3-56]

Pattern Provided by:

Judges

Lucky 7 Classic

Hunt Seat Equitation (L1 Youth, L1 Amateur, 13 & Under)

Show Date: 04-29-2026

w w w . H o r s e S h o w P a t t e r n s . c o m

w w w . H o r s e S h o w P a t t e r n s . c o m

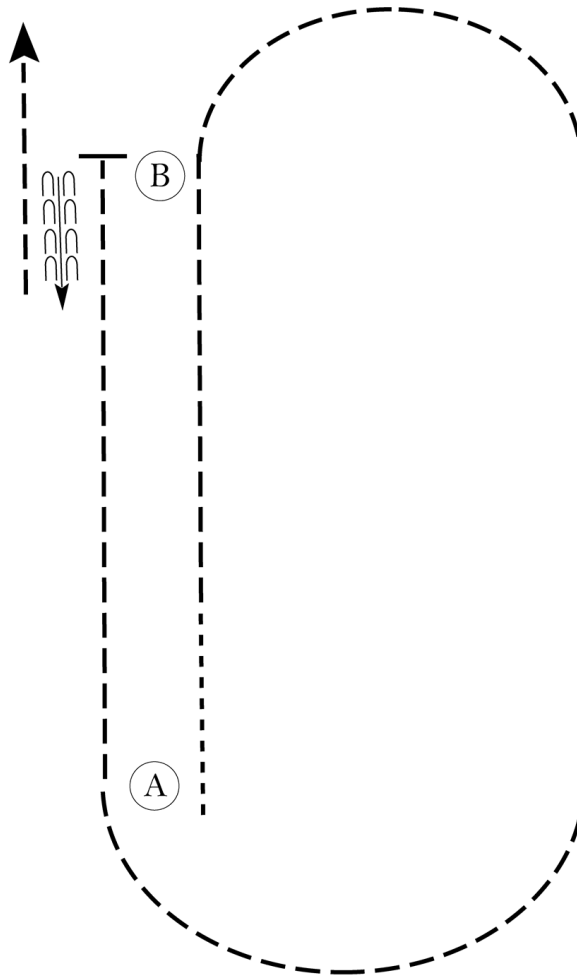

Be ready at A.

1. Walk approximately 2 horse lengths.
2. Posting trot on the left diagonal to B and in a half circle until even with B.
3. Canter on the right lead until even with A.
4. Sitting trot in a half circle to A.
5. Posting trot on the right diagonal to B.
6. Halt and back approximately one horse length.
7. Exit pattern at a sitting trot.

Follow the instructions of your ring steward.

| | |
|---------------|-----------|
| Walk | ----- |
| Trot | - - - - - |
| Extended Trot | ----- |
| Canter | ————— |
| Leg Yield | |
| Lead Change | ↙ ↘ |
| Back | ← ← ← ← ← |
| Marker | (B) |
| Sidepass | ← → |
| Hand Gallop | ————— |

[HSE/2-56]

Pattern Provided by:

Judges

RANCH RIDING - PATTERN 12

LEGEND

| | |
|--------|---------------|
| | Walk |
| | Extended Walk |
| - - - | Trot |
| - - - | Extended Trot |
| — — — | Lope |
| — — — | Extended Lope |
| ////// | Back |
| \\ | Lead Change |

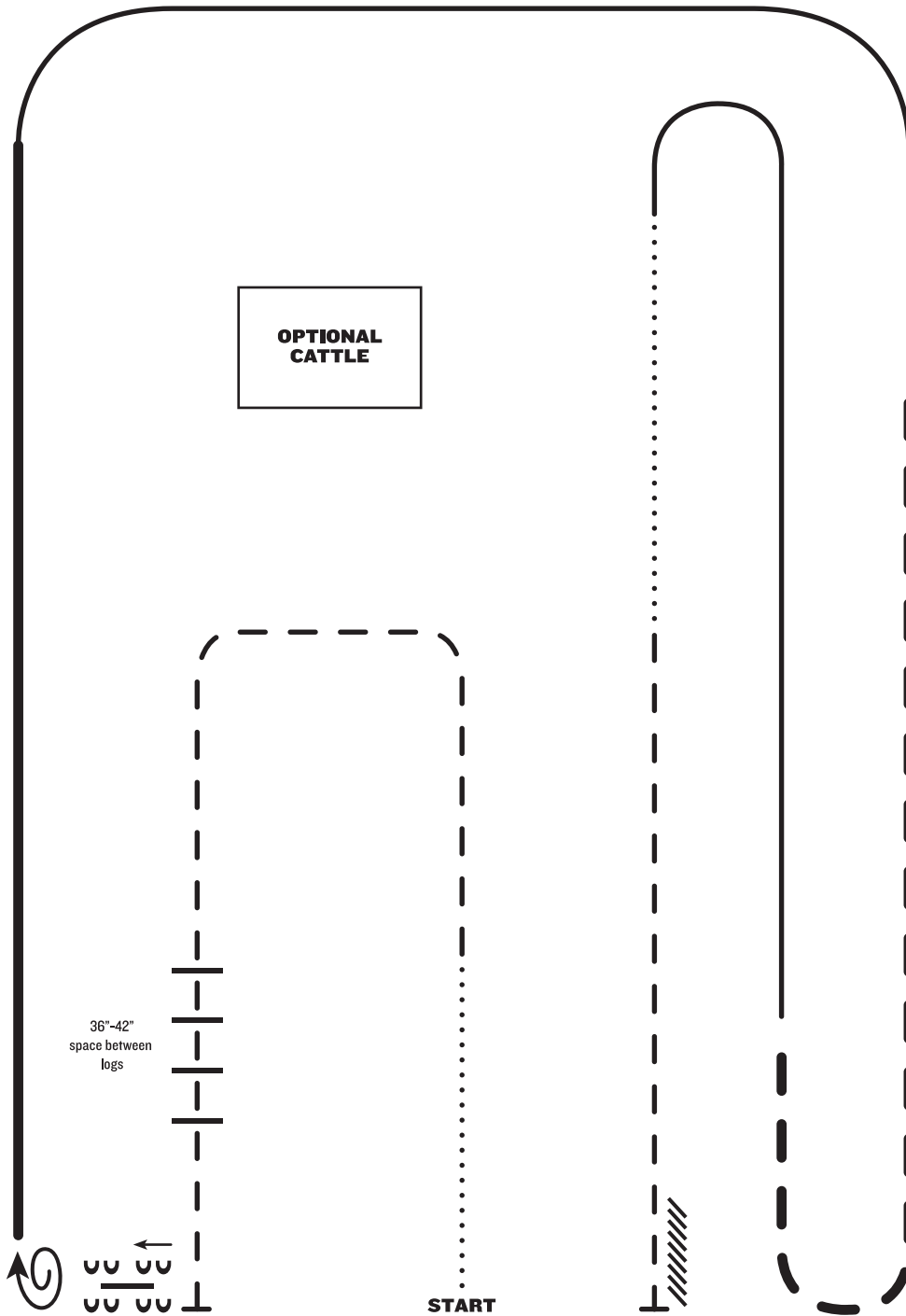

1. Walk
2. Trot
3. Trot over logs, stop
4. Side pass right over log
5. 1 1/2 turn right
6. Extended lope right lead
7. Lope right lead
8. Extended trot
9. Lope left lead
10. Walk
11. Trot
12. Stop and back

Note: The drawn description of this pattern is only intended for the general depiction of the pattern. Exhibitors should utilize the arena space to best exhibit their horses.

Saturday Sm Fry RANCH RIDING

LEGEND

| | |
|--------|---------------|
| | Walk |
| | Extended Walk |
| - - - | Trot |
| - - - | Extended Trot |
| — — — | Lope |
| — — — | Extended Lope |
| ////// | Back |
| \\ | Lead Change |

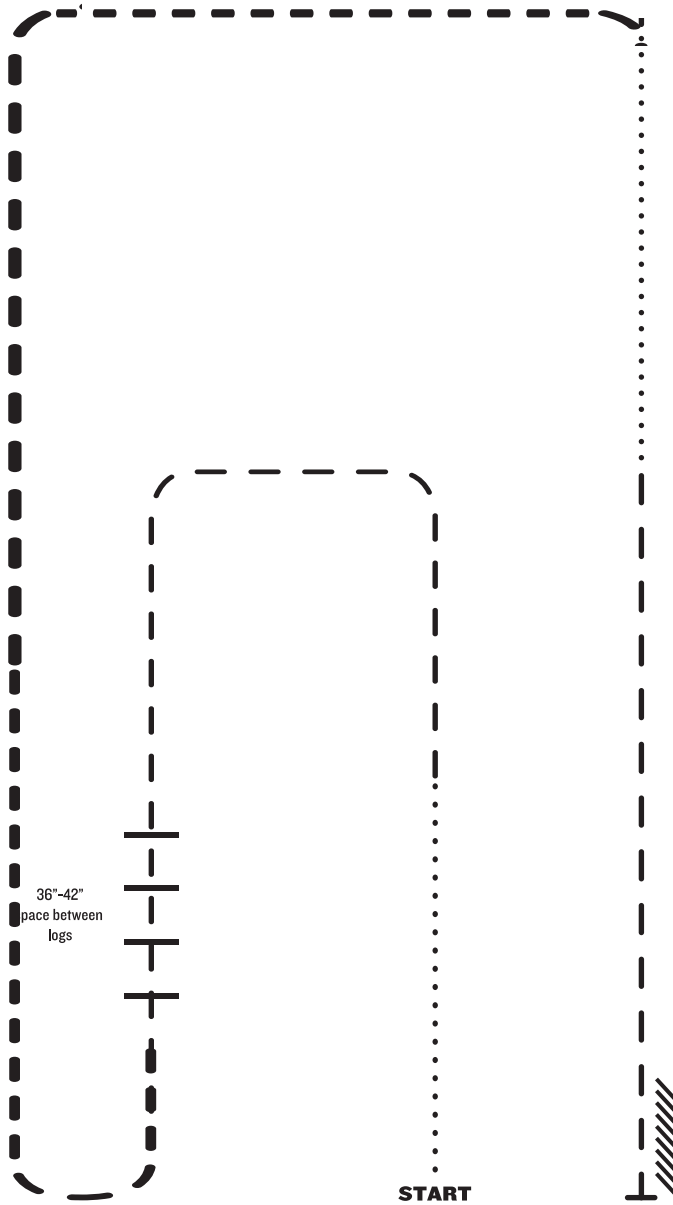

1. Walk
2. Trot
3. Trot over logs
4. Extend Trot
5. Walk
6. Trot
7. Stop and back

Note: The drawn description of this pattern is only intended for the general depiction of the pattern. Exhibitors should utilize the arena space to best exhibit their horses.

Day 4 All REINING PATTERN 10

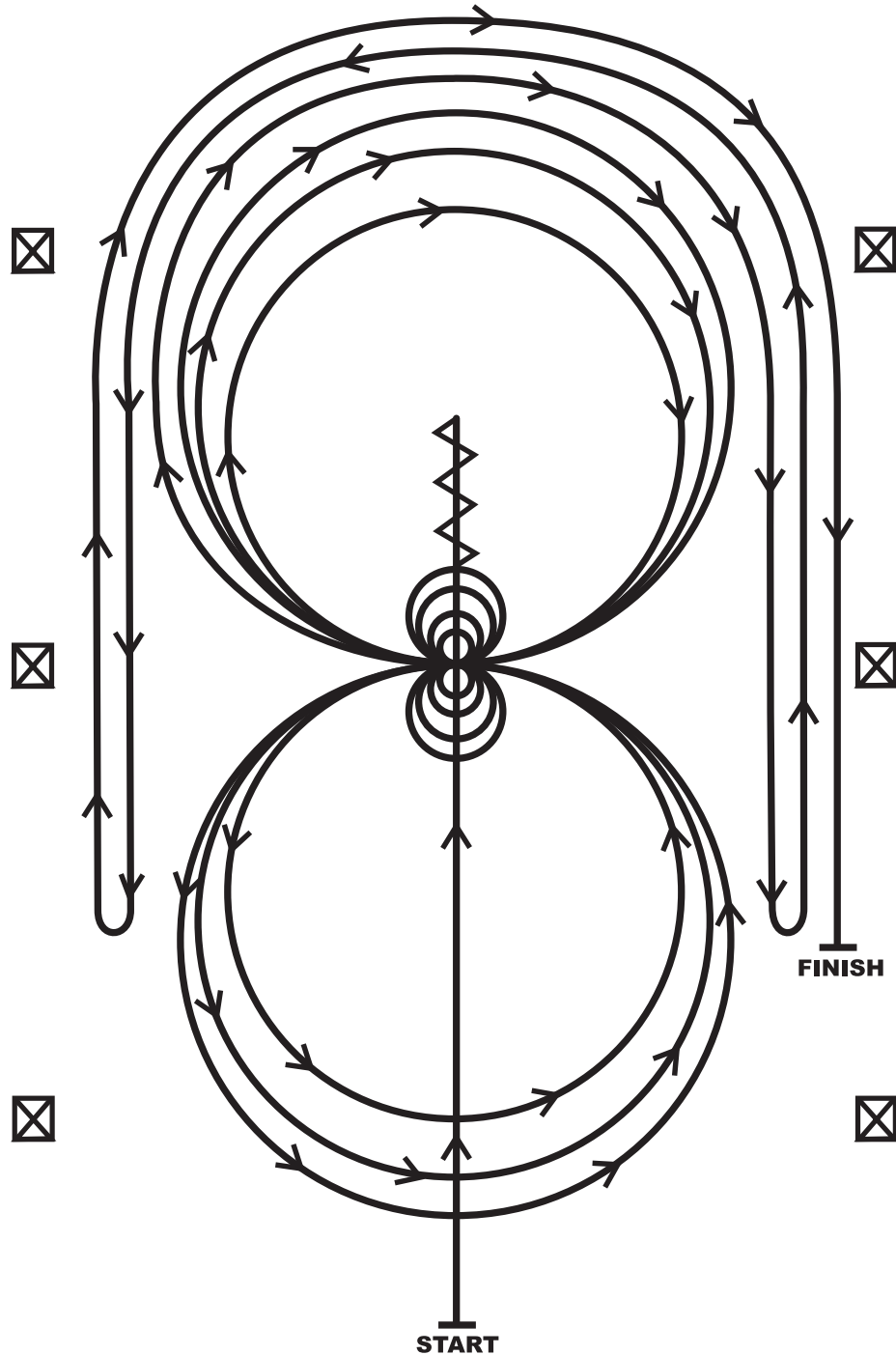

1. Run past the center marker and do a sliding stop. Back up to the center of the arena or at least ten feet (three meters). Hesitate.
2. Complete four spins to the right. Hesitate.
3. Complete four and one-quarter spins to the left so that the horse is facing the left wall or fence. Hesitate.
4. Beginning on the right lead, complete three circles to the right: the first two circles large and fast, the third circle small and slow. Change leads at the center of the arena.
5. Complete three circles to the left: the first circle small and slow, the next two circles large and fast. Change leads at the center of the arena.
6. Begin a large circle to the right but do not close this circle. Run down the right side of the arena past the center marker and do a left rollback at least twenty feet (six meters) from the wall or fence—no hesitation.
7. Continue back around the previous circle but do not close this circle. Run down the left side of the arena past the center and do a right rollback at least twenty feet (six meters) from the wall or fence—no hesitation.
8. Continue back around previous circle but do not close this circle. Run down the right side of the arena past the center marker and do a sliding stop at least twenty feet (six meters) from the wall or fence. Hesitate to demonstrate completion of the pattern.

2026 Lucky 7 Fence class courses SUNDAY

Jump each fence from the numbered side.

All Working Hunters 1,2,3,4,5,6,7,8
All Hunter Hacks 5,6

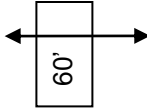
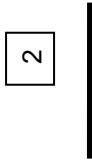
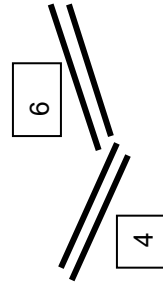
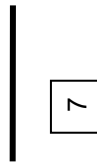
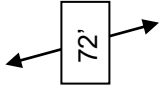
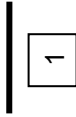
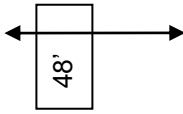
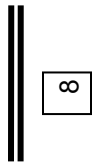

Jump each fence from the numbered side.

All Equitation over Fences 1, trot 2,3,4,5,6, DO NOT JUMP 7 or 8
Youth, Amateur, All-Age Jumpers 1,2,3,4,5,6,7,8
Jump-off 4,5,2,3

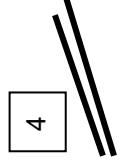
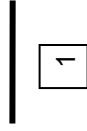
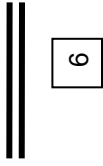
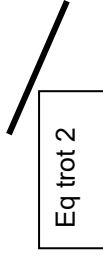

Lucky 7 Classic

Western Horsemanship (14-18 Youth, Amateur, Select)

Show Date: 04-29-2026

www.HorseShowPatterns.com

www.HorseShowPatterns.com

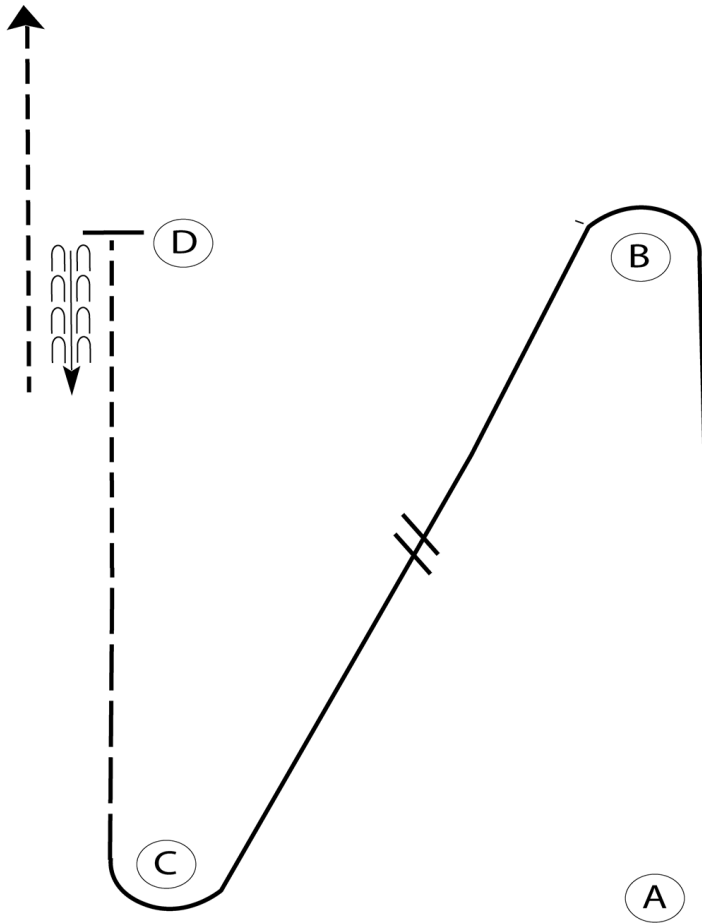

Be ready at A.

1. Walk two horse lengths from A.
2. Lope on the left lead to and around B.
3. Halfway between B and C, change leads.
4. Lope on the right lead to and around C.
5. Extend the jog halfway to D.
6. Jog to D.
7. Stop at D and back approximately one horse length
8. Exit at a jog.

| | |
|---------------------|-------------|
| Walk | ----- |
| Jog | - - - - - |
| Extended Jog | - - - - - |
| Lope | ————— |
| Leg Yield | |
| Lead Change | — / — |
| Back | ← — — — — |
| Marker | ⓑ |
| Sidepass | ← — — — — → |

Follow the instructions of your ring steward.

[WH/3-66]

Pattern Provided by:

Judges

Lucky 7 Classic

Western Horsemanship (L1 Youth, L1 Amateur, 13 & Under)

Show Date: 04-29-2026

w w w . H o r s e S h o w P a t t e r n s . c o m

w w w . H o r s e S h o w P a t t e r n s . c o m

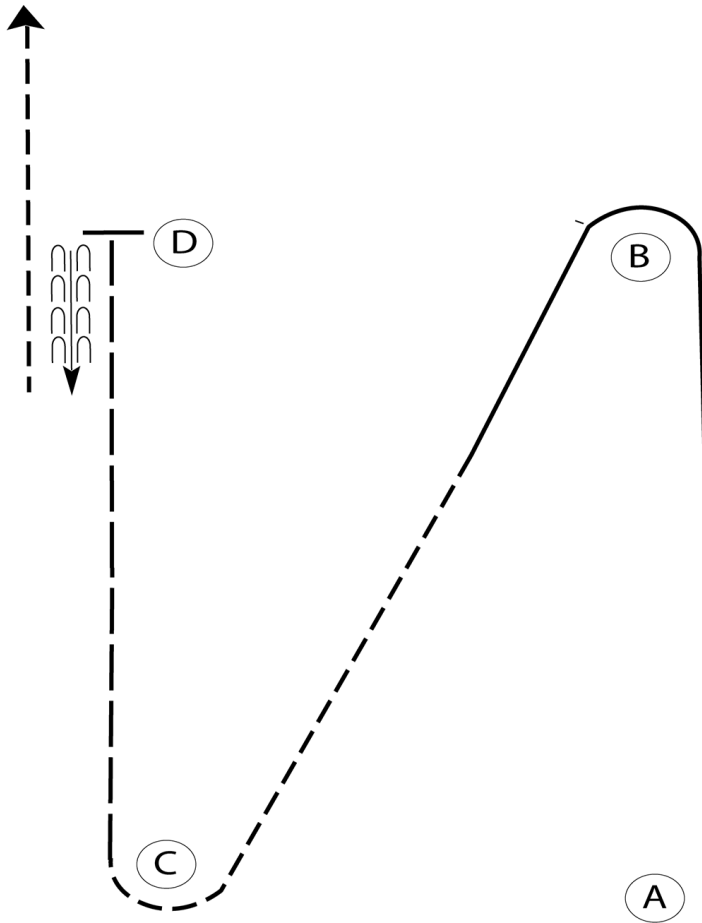

Be ready at A.

1. Walk two horse lengths from A.
2. Lope on the left lead to and around B.
3. Halfway between B and C, break to a jog.
4. Jog to and around C.
5. Extend the jog from C to D.
6. Stop at D and back approximately one horse length
7. Exit at a jog.

Follow the instructions of your ring steward.

| | |
|---------------------|-----------|
| Walk | ----- |
| Jog | - - - - - |
| Extended Jog | - - - - - |
| Lope | ————— |
| Leg Yield | |
| Lead Change | — / — |
| Back | ← c c c c |
| Marker | Ⓚ |
| Sidepass | ←-----→ |

[WH/1-66]

Pattern Provided by:

Judges

Lucky 7 Classic

Western Horsemanship (Walk Trot)

Show Date: 04-29-2026

w w w . H o r s e S h o w P a t t e r n s . c o m

w w w . H o r s e S h o w P a t t e r n s . c o m

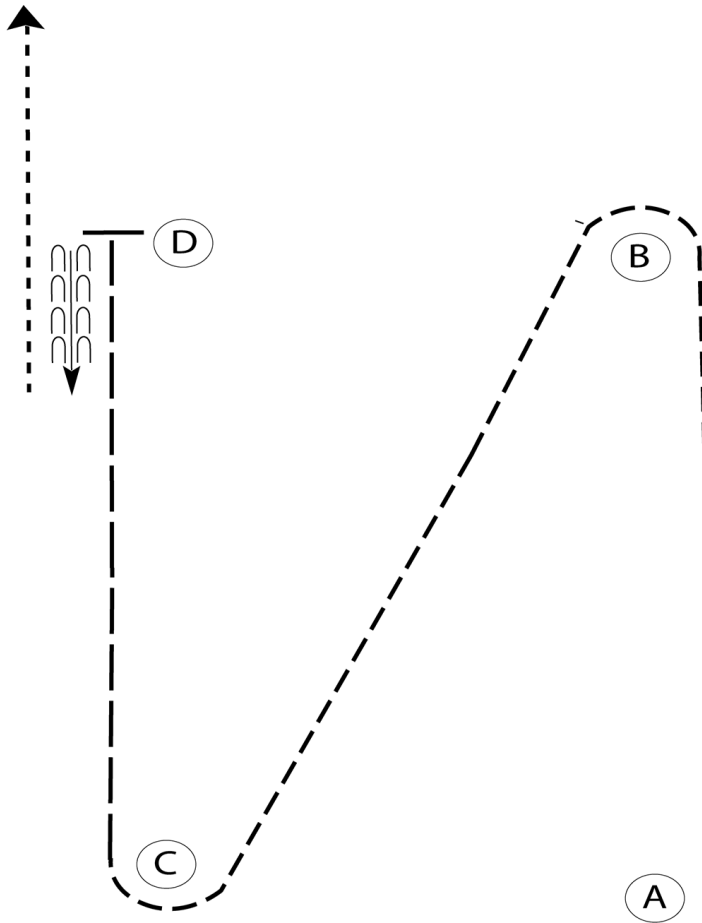

Be ready at A.

1. Walk halfway to B.
2. Jog to and around B.
3. Continue to jog to and around C.
4. Jog to and around C.
5. Extend the jog from C to D.
6. Stop at D and back approximately one horse length
7. Exit at a walk.

Follow the instructions of your ring steward.

| | |
|--------------|-----------|
| Walk | ----- |
| Jog | - - - - - |
| Extended Jog | - - - - - |
| Lope | ————— |
| Leg Yield | |
| Lead Change | — / — |
| Back | ← c c c c |
| Marker | ⓑ |
| Sidepass | ←-----→ |

[WH/WT-66]

Pattern Provided by:

Judges